

Surface Mount Multilayer Ceramic Chip Capacitors for Commodity Applications



FEATURES

- Class 3 dielectric
- Four standard sizes
- High capacitance per unit volume
- Supplied in tape on reel
- For high frequency applications
- Ni-barrier with 100 % tin terminations
- Dry sheet technology process
- Base Metal Electrode System (BME)
- Halogen-free according to IEC 61249-2-21



RoHS
COMPLIANT
HALOGEN
FREE

APPLICATIONS

- Consumer electronics
- Telecommunications
- Data processing
- Mobile applications

ELECTRICAL SPECIFICATION

Note: Electrical characteristics values - temperature at 20 °C, unless otherwise specified

Operating Temperature: - 25 °C to + 85 °C

Capacitance Range: 100 pF to 100 µF

Voltage Range: 6.3 Vdc to 100 Vdc

Temperature Coefficient of Capacitance (TCC):

+ 30 %/- 80 % without voltage applied

Dissipation Factor (DF):

6.3 V: ≤ 20 %

10 V: ≤ 12.5 %

16 V: for Cap. < 1 µF ≤ 7.0 %

≤ 9 % for 0402 ≥ 0.068 µF; 0603 ≥ 0.68 µF

≤ 12.5 % for 0402 ≥ 0.22 µF

16 V: for Cap. ≥ 1 µF ≤ 9 %

≤ 12.5 % for 0805 ≥ 3.3 µF; 1206 ≥ 10 µF; 1210 ≥ 22 µF

25 V: ≤ 5 %

≤ 7 % for 0402 ≥ 0.047 µF; 0603 ≥ 0.1 µF; 0805 ≥ 0.33 µF;

1206 ≥ 1 µF; 1210 ≥ 4.7 µF

≤ 9 % for 0402 ≥ 0.068 µF; 0603 ≥ 0.47 µF; 1206 ≥ 4.7 µF

≥ **50 V:** ≤ 5.0 %

≤ 7 % for 0603 ≥ 0.1 µF; 0805 ≥ 0.47 µF

Aging Rate:

6.3 V: 12.5 % maximum per decade

10 V/16 V: 9 % maximum per decade

≥ 25 V: 7 % maximum per decade

Insulation Resistance (IR):

10 GΩ or 500 ΩF whichever is less

Dielectric Strength Test:

This is the maximum voltage the capacitors are tested for 1 s to 5 s period and the charge/discharge current does not exceed 50 mA

≤ 100 Vdc: 250 % of rated voltage

ORDERING INFORMATION

VJ0402	V	101	J	X	Q	C	W1BC
SIZE CODE	DIELECTRIC	CAPACITANCE	TOLERANCE	TERMINATION	VOLTAGE	PACKAGING	PROCESS CODE FOR BASIC COMMODITY
0402 0603 0805 1206 1210	V = Y5V	two significant digits followed by the number of zeros: 101 = 100 pF 102 = 1000 pF 152 = 1500 pF 103 = 10 000 pF	M = ± 20 % Z = - 20 %/+ 80 %	X = Ni Barrier	Y = 6.3 V Q = 10 V J = 16 V X = 25 V A = 50 V B = 100 V	C = 7" reel/paper P = 13" reel/paper T = 7" reel/blister R = 13" reel/blister	

VJ....W1BC Y5V Dielectric



Vishay

Surface Mount Multilayer Ceramic Chip Capacitors
for Commodity Applications

SELECTION CHART																	
DIELECTRIC		Y5V															
EIA CAP. CODE	EIA SIZE CAP.	0402						0603					0805				
		6.3 V	10 V	16 V	25 V	50 V	100 V	10 V	16 V	25 V	50 V	100 V	10 V	16 V	25 V	50 V	100 V
102	1000 pF																
122	1200 pF																
152	1500 pF																
182	1800 pF																
222	2200 pF																
272	2700 pF																
332	3300 pF																
392	3900 pF																
472	4700 pF																
562	5600 pF																
682	6800 pF																
822	8200 pF																
103	0.01 µF		N	N	N	N		S	S	S	S		A	A	A	A	B
123	0.012 µF		N	N	N	N		S	S	S	S		A	A	A	A	
153	0.015 µF		N	N	N	N		S	S	S	S		A	A	A	A	B
183	0.018 µF		N	N	N	N		S	S	S	S		A	A	A	A	
223	0.022 µF		N	N	N	N		S	S	S	S		A	A	A	A	B
273	0.027 µF		N	N	N	N		S	S	S	S		A	A	A	A	
333	0.033 µF		N	N	N	N		S	S	S	S		A	A	A	A	B
393	0.039 µF		N	N	N			S	S	S	S		A	A	A	A	
473	0.047 µF		N	N	N			S	S	S	S		A	A	A	A	B
563	0.056 µF		N	N	N			S	S	S	S		A	A	A	A	
683	0.068 µF		N	N	N			S	S	S	S		A	A	A	A	B
823	0.082 µF		N	N	N			S	S	S	S		A	A	A	A	
104	0.1 µF		N	N	N			S	S	S	S		A	A	A	A	B
154	0.15 µF		N					S	S	S	S		A	A	A	A	
224	0.22 µF	N	N					S	S	S	S		A	A	A	A	
334	0.33 µF	N	N					S	S	S			B	B	B	B	
474	0.47 µF	N	N					S	S				B	B	B	B	
684	0.68 µF	N						S	X				B	B	D	D	
105	1 µF	N						S	X	X			B	B	D	D	
155	1.5 µF							S					D	D			
225	2.2 µF							S					D	D	I		
335	3.3 µF												D	D			
475	4.7 µF												D	D	I		
685	6.8 µF												I				
106	10 µF												I				
226	22 µF																
336	33 µF																
476	47 µF																
686	68 µF																
107	100 µF																

Note

- Letters indicate product thickness, please see packaging quantities



VJ....W1BC Y5V Dielectric

Surface Mount Multilayer Ceramic Chip Capacitors
for Commodity Applications

Vishay

SELECTION CHART												
DIELECTRIC		Y5V										
EIA CAP. CODE	EIA SIZE	1206					1210					
	CAP.	10 V	16 V	25 V	50 V	100 V	6.3 V	10 V	16 V	25 V	50 V	100 V
102	1000 pF											
122	1200 pF											
152	1500 pF											
182	1800 pF											
222	2200 pF											
272	2700 pF											
332	3300 pF											
392	3900 pF											
472	4700 pF											
562	5600 pF											
682	6800 pF											
822	8200 pF											
103	0.01 μF	B	B	B	B	B						C
123	0.012 μF	B	B	B	B							
153	0.015 μF	B	B	B	B	B						C
183	0.018 μF	B	B	B	B							
223	0.022 μF	B	B	B	B	B						C
273	0.027 μF	B	B	B	B							
333	0.033 μF	B	B	B	B	B						C
393	0.039 μF	B	B	B	B							
473	0.047 μF	B	B	B	B	B						C
563	0.056 μF	B	B	B	B							
683	0.068 μF	B	B	B	B	B						C
823	0.082 μF	B	B	B	B							
104	0.1 μF	B	B	B	B	B		C	C	C	C	C
154	0.15 μF	B	B	B	B	C		C	C	C	C	C
224	0.22 μF	B	B	B	B	C		C	C	C	C	C
334	0.33 μF	B	B	B	B			C	C	C	C	C
474	0.47 μF	B	B	B	B			C	C	C	C	
684	0.68 μF	B	B	B	B			C	C	C	C	
105	1 μF	C	C	C	C			C	C	C	C	
155	1.5 μF	C	C	C				C	C	C		
225	2.2 μF	C	C	C	J ⁽¹⁾			C	C	C	G	
335	3.3 μF	J	J	J				C	C	C		
475	4.7 μF	J	J	J				C	C	D	G	
685	6.8 μF	J	J					C	C	D		
106	10 μF	J	J					D	D	G		
226	22 μF	P						K	K			
336	33 μF											
476	47 μF						K	K				
686	68 μF											
107	100 μF						M					

Notes

- ⁽¹⁾ Not in 20 % (code "M") tolerance
- Letters indicate product thickness, please see packaging quantities

VJ....W1BC Y5V Dielectric



Vishay

Surface Mount Multilayer Ceramic Chip Capacitors
for Commodity Applications

DIMENSIONS in inches [millimeters]					
	SIZE CODE	L	W	T MAX.	MB
	0402 (1005)	0.040 ± 0.002 [1.00 ± 0.05]	0.020 ± 0.002 [0.50 ± 0.05]	0.022 [0.55]	0.010 ± 0.004 [0.25 ± 0.10]
	0603 (1608)	0.063 + 0.006/- 0.004 [1.60 + 0.15/- 0.10]	0.030 + 0.006/- 0.004 [0.80 + 0.15/- 0.10]	0.038 [0.95]	0.012 - 0.008/+ 0.010 [0.30 - 0.20/+ 0.25]
	0805 (2012)	0.080 ± 0.008 [2.00 ± 0.20]	0.050 ± 0.008 [1.25 ± 0.20]	0.057 [1.45]	0.020 - 0.012/+ 0.008 [0.50 - 0.30/+ 0.20]
	1206 (3216)	0.125 + 0.012/- 0.008 [3.20 + 0.30/- 0.20]	0.063 + 0.012/- 0.008 [1.60 + 0.30/- 0.20]	0.075 [1.90]	0.020 ± 0.012 [0.50 ± 0.30]
	1210 (3225)	0.126 ± 0.016 [3.20 ± 0.40]	0.098 ± 0.012 [2.50 ± 0.30]	0.110 [2.80]	0.026 ± 0.014 [0.65 ± 0.35]

STORAGE AND HANDLING CONDITIONS

- (1) To store products at 5 °C to 40 °C ambient temperature and 20 % to 70 % related humidity conditions.
- (2) The product is recommended to be used within one year after shipment. Check solderability in case of shelf life extension is needed.

Cautions:

- a. Don't store products in a corrosive environment such as sulfide, chloride gas, or acid. It may cause oxidization of electrode, which easily be resulted in poor soldering.
- b. To store products on the shelf and avoid exposure to moisture.
- c. Don't expose products to excessive shock, vibration, direct sunlight and so on.

PACKAGING QUANTITIES						
SIZE CODE (inch/mm)	MAX. THICKNESS (mm)	THICKNESS SYMBOL	PAPER TAPE		PLASTIC TAPE	
			7" reel (C)	13" reel (P)	7" reel (T)	13" reel (R)
0402 (1002)	0.55	N	10K	50K		
0603 (1608)	0.90	S	4K	15K		
	0.95	X	4K	15K		
0805 (2012)	0.75	A	4K	15K		
	0.95	B	4K	15K		
	1.40	D			3K	10K
	1.45	I			3K	10K
1206 (3216)	0.95	B	4K	15K		
	1.05	C			3K	10K
	1.30	J			3K	10K
	1.35	D			3K	10K
	1.80	G			2K	
	1.80	H			2K	8K
	1.90	P			2K	
1210 (3225)	1.05	B			2K	10K
	1.05	C			3K	10K
	1.35	D			3K	10K
	1.80	G			2K	
	2.00	U			2K	4K
	2.20	K			1K	
	2.70	J			1K	4K
	2.80	M			1K	
2.80	V			1K	4K	

PAPER TAPE SPECIFICATIONS

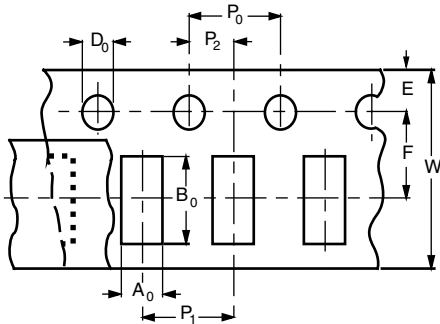

DIMENSIONS OF PAPER TAPE

in millimeters

SYM.	PRODUCT SIZE CODE			
	0402	0603	0805	1206
A_0	0.62 ± 0.05	1.02 ± 0.05	1.50 ± 0.10	2.00 ± 0.10
B_0	1.12 ± 0.05	1.82 ± 0.05	2.30 ± 0.10	3.50 ± 0.10
W	8.00 ± 0.10	8.00 ± 0.10	8.00 ± 0.10	8.00 ± 0.10
E	1.75 ± 0.05	1.75 ± 0.05	1.75 ± 0.05	1.75 ± 0.10
F	3.50 ± 0.05	3.50 ± 0.05	3.50 ± 0.05	3.50 ± 0.05
D_0	1.55 ± 0.05	1.55 ± 0.05	1.55 ± 0.05	1.50 ± 0.05
P_0	4.00 ± 0.10	4.00 ± 0.10	4.00 ± 0.10	4.00 ± 0.10
P_1	2.00 ± 0.05	4.00 ± 0.10	4.00 ± 0.10	4.00 ± 0.10
P_2	2.00 ± 0.05	2.00 ± 0.05	2.00 ± 0.05	2.00 ± 0.05

BLISTER TAPE SPECIFICATIONS

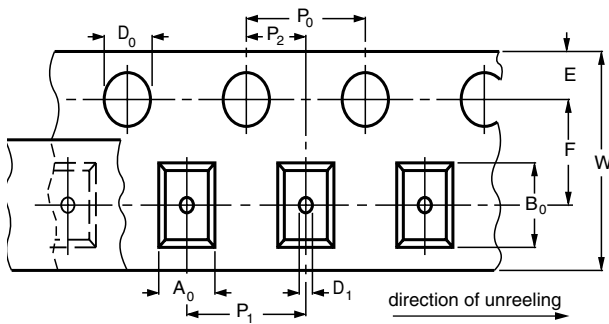

DIMENSIONS OF BLISTER TAPE

in millimeters

SYM.	PRODUCT SIZE CODE		
	0805	1206	1210
A_0	< 1.57	< 2.00	< 2.97
B_0	< 2.45	< 3.70	< 3.73
W	8.00 ± 0.10	8.00 ± 0.10	8.00 ± 0.10
E	1.75 ± 0.10	1.75 ± 0.10	1.75 ± 0.10
F	3.50 ± 0.05	3.50 ± 0.05	3.50 ± 0.05
D_0	1.50 ± 0.05	1.50 ± 0.05	1.50 ± 0.05
D_1	1.00 ± 0.10	1.00 ± 0.10	1.00 ± 0.10
P_0	4.00 ± 0.10	4.00 ± 0.10	4.00 ± 0.10
P_1	4.00 ± 0.10	4.00 ± 0.10	4.00 ± 0.10
P_2	2.00 ± 0.05	2.00 ± 0.05	2.00 ± 0.05

REEL SPECIFICATIONS

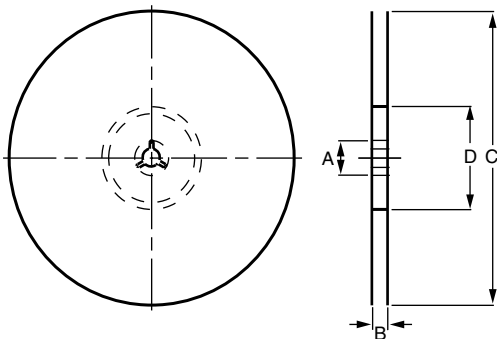

REEL DIMENSIONS AND TAPE WIDTH

in millimeters

	Ø 180 mm; 7"	Ø 330 mm; 13"
A	13.0 ± 0.5	13.0 ± 0.5
B	9.0 ± 1.0	9.0 ± 1.0
C	178.0 ± 1.0	330.0 ± 1.0
D	60.0 ± 1.0	100.0 ± 1.0



Disclaimer

All product specifications and data are subject to change without notice.

Vishay Intertechnology, Inc., its affiliates, agents, and employees, and all persons acting on its or their behalf (collectively, "Vishay"), disclaim any and all liability for any errors, inaccuracies or incompleteness contained herein or in any other disclosure relating to any product.

Vishay disclaims any and all liability arising out of the use or application of any product described herein or of any information provided herein to the maximum extent permitted by law. The product specifications do not expand or otherwise modify Vishay's terms and conditions of purchase, including but not limited to the warranty expressed therein, which apply to these products.

No license, express or implied, by estoppel or otherwise, to any intellectual property rights is granted by this document or by any conduct of Vishay.

The products shown herein are not designed for use in medical, life-saving, or life-sustaining applications unless otherwise expressly indicated. Customers using or selling Vishay products not expressly indicated for use in such applications do so entirely at their own risk and agree to fully indemnify Vishay for any damages arising or resulting from such use or sale. Please contact authorized Vishay personnel to obtain written terms and conditions regarding products designed for such applications.

Product names and markings noted herein may be trademarks of their respective owners.