

# DATA SHEET

## GENERAL PURPOSE CHIP RESISTORS

RC0201  
5%, 1%  
RoHS compliant



**SCOPE**

This specification describes RC0201 series chip resistors with lead-free terminations made by thick film process.

**APPLICATIONS**

- All general purpose application

**FEATURES**

- RoHS compliant
  - Products with lead free terminations meet RoHS requirements
  - Pb-glass contained in electrodes
  - Resistor element and glass are exempted by RoHS
- Reducing environmentally hazardous wastes
- High component and equipment reliability
- Saving of PCB space
- None forbidden-materials used in products/production
- Halogen Free Epoxy

**ORDERING INFORMATION - GLOBAL PART NUMBER & I2NC**

Both part numbers are identified by the series, size, tolerance, packing type, temperature coefficient, taping reel and resistance value.

**YAGEO BRAND ordering code**

**GLOBAL PART NUMBER (PREFERRED)**

**RC0201** **X** **R** - **XX** **XXXX** **L**  
 (1) (2) (3) (4) (5) (6)

**(1) TOLERANCE**

F = ±1%  
 J = ±5% (for Jumper ordering, use code of J)

**(2) PACKAGING TYPE**

R = Paper taping reel

**(3) TEMPERATURE COEFFICIENT OF RESISTANCE**

- = Base on spec

**(4) TAPING REEL**

07 = 7 inch dia. Reel  
 10 = 10 inch dia. Reel  
 13 = 13 inch dia. Reel

**(5) RESISTANCE VALUE**

There are 2~4 digits indicated the resistor value. Letter R/K/M is decimal point, no need to mention the last zero after R/K/M, e.g.1K2, not 1K20.  
 Detailed resistance rules show in table of "Resistance rule of global part number".

**(6) OPTIONAL CODE**

L = optional symbol (Note)

| Resistance rule of global part number |                              |
|---------------------------------------|------------------------------|
| Resistance code rule                  | Example                      |
| DI                                    | DI = Dummy                   |
| OR                                    | OR = Jumper                  |
| XRXX                                  | 1R = 1 Ω                     |
| (1 to 9.76 Ω)                         | 1R5 = 1.5 Ω<br>9R76 = 9.76 Ω |
| XXRX                                  | 10R = 10 Ω                   |
| (10 to 97.6 Ω)                        | 97R6 = 97.6 Ω                |
| XXXR                                  | 100R = 100 Ω                 |
| (100 to 976 Ω)                        |                              |
| XKXX                                  | 1K = 1,000 Ω                 |
| (1 to 9.76 KΩ)                        | 9K76 = 9760 Ω                |
| XMXX                                  | 1M = 1,000,000 Ω             |
| (1 to 9.76 MΩ)                        | 9M76 = 9,760,000 Ω           |

**ORDERING EXAMPLE**

The ordering code of a RC0201 chip resistor, value 56 Ω with ±1% tolerance, supplied in 7-inch tape reel is: RC0201FR-0756R(L).

**NOTE**

1. All our RSMD products meet RoHS compliant. "LFP" of the internal 2D reel label mentions "Lead Free Process"
2. On customized label, "LFP" or specific symbol printed and the optional "L" at the end of GLOBAL PART NUMBER / I2NC can be added (both are on customer request)

**PHYCOMP BRAND ordering codes**

Both GLOBAL PART NUMBER (preferred) and I2NC (traditional) codes are acceptable to order Phycomp brand products.

**GLOBAL PART NUMBER (PREFERRED)**

For detailed information of GLOBAL PART NUMBER and ordering example, please refer to page 2.

**I2NC CODE**

| TYPE/<br>0201 | 2322 | TOL.<br>(%) | XXX | XXXXX | L   | PAPER / PE TAPE ON REEL (units) <sup>(2)</sup> |           |           |
|---------------|------|-------------|-----|-------|-----|------------------------------------------------|-----------|-----------|
|               | (1)  |             | (2) | (3)   | (4) | 10,000                                         | 20,000    | 50,000    |
| RC41          | 2322 | ±5%         | 1   | to 1  | MΩ  | 803 70xxx                                      | 806 80xxx | 803 60xxx |
| RC42          | 2322 | ±1%         | 1   | to 1  | MΩ  | 806 7xxxx                                      | 806 8xxxx | 806 6xxxx |
| Jumper        | 2322 | -           | 0   | Ω     |     | 803 91001                                      | ---       | ---       |
| Dummy         | 2322 | -           | -   |       |     | 803 93001                                      | ---       | ---       |

| Resistance decade <sup>(3)</sup> | Last digit |
|----------------------------------|------------|
| 0.01 to 0.0976 Ω                 | 0          |
| 0.1 to 0.976 Ω                   | 7          |
| 1 to 9.76 Ω                      | 8          |
| 10 to 97.6 Ω                     | 9          |
| 100 to 976 Ω                     | 1          |
| 1 to 9.76 KΩ                     | 2          |
| 10 to 97.6 KΩ                    | 3          |
| 100 to 976 KΩ                    | 4          |
| 1 to 9.76 MΩ                     | 5          |
| 10 to 97.6 MΩ                    | 6          |

- (1) The resistors have a 12-digit ordering code starting with 2322.
- (2) The subsequent 4 or 5 digits indicate the resistor tolerance and packaging.
- (3) The remaining 4 or 3 digits represent the resistance value with the last digit indicating the multiplier as shown in the table of "Last digit of I2NC".
- (4) "L" is optional symbol <sup>(Note)</sup>.

Example:

|        |   |             |
|--------|---|-------------|
| 0.02 Ω | = | 0200 or 200 |
| 0.3 Ω  | = | 3007 or 307 |
| 1 Ω    | = | 1008 or 108 |
| 33 KΩ  | = | 3303 or 333 |
| 10 MΩ  | = | 1006 or 106 |

**ORDERING EXAMPLE**

The ordering code of a RC42 resistor, value 56 Ω with ±1% tolerance, supplied in tape of 10,000 units per reel is: 232280675609(L) or RC0201FR-0756R(L).

**NOTE**

- 1. All our RSMD products are RoHS compliant. "LFP" of the internal 2D reel label mentions "Lead Free Process"
- 2. On customized label, "LFP" or specific symbol printed and the optional "L" at the end of GLOBAL PART NUMBER / I2NC can be added (both are on customer request)

**MARKING**

RC0201

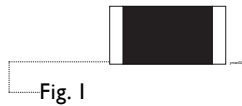

No marking

For further marking information, please see special data sheet “Chip resistors marking”.

**CONSTRUCTION**

The resistor is constructed on top of a high-grade ceramic body. Internal metal electrodes are added on each end to make the contacts to the thick film resistive element. The composition of the resistive element is a noble metal imbedded into a glass and covered by a second glass to prevent environment influences. The resistor is laser trimmed to the rated resistance value. The resistor is covered with a protective epoxy coat, finally the two external terminations (matte tin on Ni-barrier) are added. See fig.2

**DIMENSIONS**

Table I

| TYPE                | RC0201     |
|---------------------|------------|
| L (mm)              | 0.60 ±0.03 |
| W (mm)              | 0.30 ±0.03 |
| H (mm)              | 0.23 ±0.03 |
| l <sub>1</sub> (mm) | 0.10 ±0.05 |
| l <sub>2</sub> (mm) | 0.15 ±0.05 |

**OUTLINES**

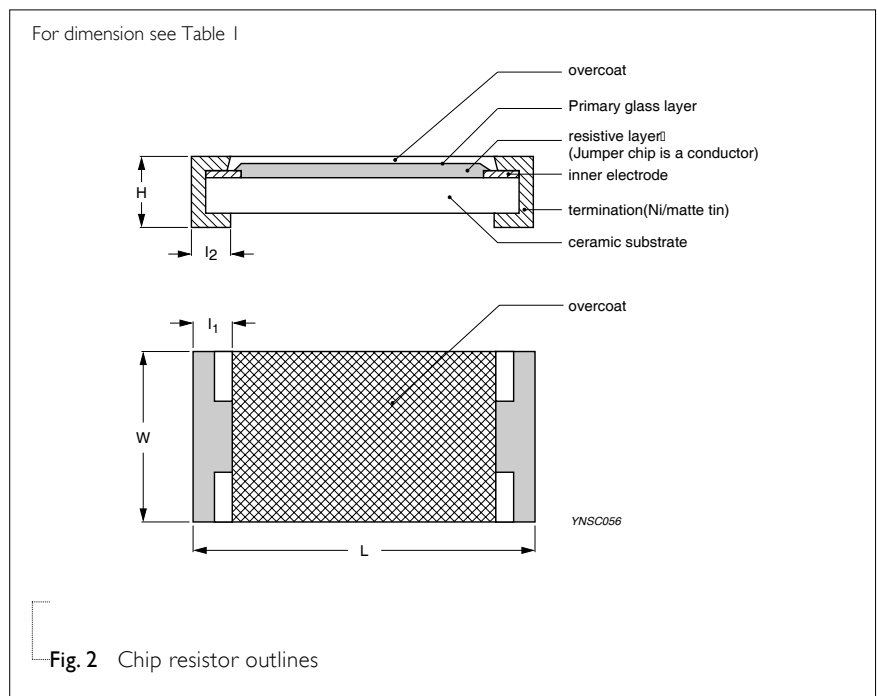

**ELECTRICAL CHARACTERISTICS**

Table 2

| CHARACTERISTICS                 | RC0201 1/20 W                   |
|---------------------------------|---------------------------------|
| Operating Temperature Range     | -55 °C to +125 °C               |
| Maximum Working Voltage         | 25 V                            |
| Maximum Overload Voltage        | 50 V                            |
| Dielectric Withstanding Voltage | 50 V                            |
| Resistance Range                | 5% (E24) 1 Ω to 10 MΩ           |
|                                 | 1% (E24/E96) 1 Ω to 1 MΩ        |
|                                 | Zero Ohm Jumper < 0.05 Ω        |
| Temperature Coefficient         | 1 Ω ≤ R ≤ 10 Ω -100/+350 ppm/°C |
|                                 | 10 Ω < R ≤ 10 MΩ ±200 ppm/°C    |
| Jumper Criteria                 | Rated Current 0.5 A             |
|                                 | Maximum Current 1.0 A           |

**FOOTPRINT AND SOLDERING PROFILES**

For recommended footprint and soldering profiles, please see the special data sheet “Chip resistors mounting”.

**PACKING STYLE AND PACKAGING QUANTITY**

Table 3 Packing style and packaging quantity

| PRODUCT TYPE | PACKING STYLE         | REEL DIMENSION | QUANTITY PER REEL |
|--------------|-----------------------|----------------|-------------------|
| RC0201       | Paper Taping Reel (R) | 7" (178 mm)    | 10,000 units      |
|              |                       | 10" (254 mm)   | 20,000 units      |
|              |                       | 13" (330 mm)   | 50,000 units      |

**NOTE**

1. For paper tape and reel specification/dimensions, please see the special data sheet “Packing” document.

**FUNCTIONAL DESCRIPTION**

**POWER RATING**

RC0201 rated power at 70°C is 1/20 W

**RATED VOLTAGE**

The DC or AC (rms) continuous working voltage corresponding to the rated power is determined by the following formula:

$$V = \sqrt{P \times R}$$

or max. working voltage whichever is less

Where

V=Continuous rated DC or AC (rms) working voltage (V)

P=Rated power (W)

R=Resistance value (Ω)

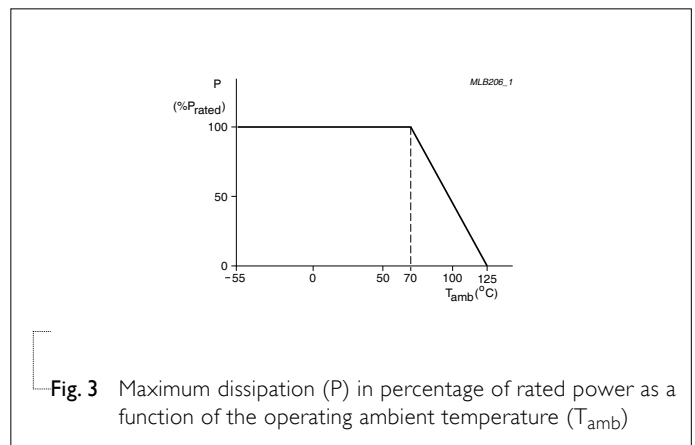

Fig. 3 Maximum dissipation (P) in percentage of rated power as a function of the operating ambient temperature (T<sub>amb</sub>)

**TESTS AND REQUIREMENTS**
**Table 4** Test condition, procedure and requirements

| TEST                                                                              | TEST METHOD              | PROCEDURE                                                                                                                                                                               | REQUIREMENTS                           |
|-----------------------------------------------------------------------------------|--------------------------|-----------------------------------------------------------------------------------------------------------------------------------------------------------------------------------------|----------------------------------------|
| Life/<br>Operational Life/<br>Endurance                                           | MIL-STD-202G-method 108A | 1,000 hours at 70±5 °C applied RCWV                                                                                                                                                     | ±(2%+0.05 Ω)                           |
|                                                                                   | IEC 60115-1 4.25.1       | 1.5 hours on, 0.5 hour off, still air required                                                                                                                                          | <100 mΩ for Jumper                     |
|                                                                                   | JIS C 5202-7.10          |                                                                                                                                                                                         |                                        |
| High<br>Temperature<br>Exposure/<br>Endurance at<br>upper category<br>temperature | MIL-STD-202G-method 108A | 1,000 hours at maximum operating temperature                                                                                                                                            | ±(1%+0.05 Ω)                           |
|                                                                                   | IEC 60115-1 4.25.3       | depending on specification, unpowered                                                                                                                                                   | <50 mΩ for Jumper                      |
|                                                                                   | JIS C 5202-7.11          | No direct impingement of forced air to the parts<br>Tolerances: 125±3 °C                                                                                                                |                                        |
| Moisture<br>Resistance                                                            | MIL-STD-202G-method 106F | Each temperature / humidity cycle is defined at 8                                                                                                                                       | ±(2%+0.05 Ω)                           |
|                                                                                   | IEC 60115-1 4.24.2       | hours (method 106F), 3 cycles / 24 hours for 10d                                                                                                                                        | <100 mΩ for Jumper                     |
|                                                                                   |                          | with 25 °C / 65 °C 95% R.H, without steps 7a &<br>7b, unpowered<br>Parts mounted on test-boards, without<br>condensation on parts<br>Measurement at 24±2 hours after<br>test conclusion |                                        |
| Thermal Shock                                                                     | MIL-STD-202G-method 107G | -55/+125 °C                                                                                                                                                                             | ±(0.5%+0.05 Ω) for 10 KΩ to            |
|                                                                                   |                          | Note: Number of cycles required is 300. Devices                                                                                                                                         | 10 MΩ                                  |
|                                                                                   |                          | unmounted                                                                                                                                                                               | ±(1%+0.05 Ω) for others                |
|                                                                                   |                          | Maximum transfer time is 20 seconds. Dwell time                                                                                                                                         | <50 mΩ for Jumper                      |
|                                                                                   |                          | is 15 minutes. Air – Air                                                                                                                                                                |                                        |
| Short time<br>overload                                                            | MIL-R-55342D-para 4.7.5  | 2.5 times RCWV or maximum overload voltage                                                                                                                                              | ±(2%+0.05 Ω)                           |
|                                                                                   | IEC60115-1 4.13          | whichever is less for 5 sec at room temperature                                                                                                                                         | <50 mΩ for Jumper<br>No visible damage |
| Board Flex/<br>Bending                                                            | IEC60115-1 4.33          | Device mounted on PCB test board as described,                                                                                                                                          | ±(1%+0.05 Ω)                           |
|                                                                                   |                          | only 1 board bending required                                                                                                                                                           | <50 mΩ for Jumper                      |
|                                                                                   |                          | 3 mm bending                                                                                                                                                                            | No visible damage                      |
|                                                                                   |                          | Bending time: 60±5 seconds                                                                                                                                                              |                                        |
|                                                                                   |                          | Ohmic value checked during bending                                                                                                                                                      |                                        |

| TEST                              | TEST METHOD                                  | PROCEDURE                                                                                                                                                                                                                            | REQUIREMENTS                                           |
|-----------------------------------|----------------------------------------------|--------------------------------------------------------------------------------------------------------------------------------------------------------------------------------------------------------------------------------------|--------------------------------------------------------|
| <b>Solderability</b><br>- Wetting | IPC/JEDECJ-STD-002B test B<br>IEC 60068-2-58 | Electrical Test not required<br>Magnification 50X<br>SMD conditions:<br>1 <sup>st</sup> step: method B, aging 4 hours at 155 °C<br>dry heat<br>2 <sup>nd</sup> step: leadfree solder bath at 245±3 °C<br>Dipping time: 3±0.5 seconds | Well tinned (≥95% covered)<br>No visible damage        |
| - Leaching                        | IPC/JEDECJ-STD-002B test D<br>IEC 60068-2-58 | Leadfree solder, 260 °C, 30 seconds<br>immersion time                                                                                                                                                                                | No visible damage                                      |
| - Resistance to Soldering Heat    | MIL-STD-202G-method 210F<br>IEC 60068-2-58   | Condition B, no pre-heat of samples<br>Leadfree solder, 270 °C, 10 seconds<br>immersion time<br>Procedure 2 for SMD: devices fluxed and<br>cleaned with isopropanol                                                                  | ±(1%+0.05 Ω)<br><50 mΩ for Jumper<br>No visible damage |

REVISION HISTORY

| REVISION  | DATE         | CHANGE NOTIFICATION | DESCRIPTION                                                                                                                                                                                                                                                                                                                                |
|-----------|--------------|---------------------|--------------------------------------------------------------------------------------------------------------------------------------------------------------------------------------------------------------------------------------------------------------------------------------------------------------------------------------------|
| Version 4 | Jul 15, 2008 | -                   | <ul style="list-style-type: none"> <li>- Description of "Halogen Free Epoxy" added</li> <li>- Define global part number</li> </ul>                                                                                                                                                                                                         |
| Version 3 | Apr 25, 2007 | -                   | <ul style="list-style-type: none"> <li>- New datasheet for 0201 thick film 1% and 5% with lead-free terminations</li> <li>- Replace the 0201 part of pdf files: Pu-RC0201_5I_PbFree_L_2 and Yu-RC0201_5I_PbFree_L_2</li> <li>- Max. working voltage, resistance rage, and TCR updated</li> <li>- Tests and Requirements updated</li> </ul> |
| Version 2 | Sep 03, 2004 | -                   | <ul style="list-style-type: none"> <li>- New datasheet for 0201 thick film 1% and 5% with lead-free terminations</li> <li>- Replace the 0201 part of pdf files: RC41_5_4, RC42_1_1</li> <li>- Test method and procedure updated</li> <li>- PE tape added (paper tape will be replaced by PE tape)</li> </ul>                               |

*“ Yageo reserves all the rights for revising the content of this datasheet without further notification, as long as the products itself are unchanged. Any product change will be announced by PCN.”*