

DATA SHEET

GENERAL PURPOSE CHIP RESISTORS

RC0201
5%, 1%
RoHS compliant



SCOPE

This specification describes RC0201 series chip resistors with lead-free terminations made by thick film process.

APPLICATIONS

- All general purpose application

FEATURES

- RoHS compliant
- Reducing environmentally hazardous wastes
- High component and equipment reliability
- Saving of PCB space
- Products with lead free terminations meet RoHS requirements.
- None of the forbidden materials are used in products / production. The Pb-glass contained in electrodes, resistor element and glass is exempted by RoHS.

ORDERING INFORMATION - I2NC & GLOBAL CLEAR TEXT CODE

Both part numbers are identified by the series, size, tolerance, packing type, temperature coefficient, taping reel and resistance value.

YAGEO BRAND ordering code

GLOBAL CTC CODE

RC0201 X R - XX XXXX L
 (1) (2) (3) (4) (5) (6)

(1) TOLERANCE

F = ±1%
 J = ±5% (for Jumper ordering, use code of J)

(2) PACKAGING TYPE

R = Paper taping reel

(3) TEMPERATURE COEFFICIENT OF RESISTANCE

- = Base on spec

(4) TAPING REEL

07 = 7 inch dia. Reel
 10 = 10 inch dia. Reel
 13 = 13 inch dia. Reel

(5) RESISTANCE VALUE

There are 2~4 digits indicated the resistor value. Letter R/K/M is decimal point, no need to mention the last zero after R/K/M, e.g. 1K2, not 1K20.
 Detailed resistance rules show in table of "Resistance rule of global CTC".

(6) OPTIONAL CODE

L = optional symbol (Note)

Resistance rule of global CTC	
Resistance code rule	Example
D1	D1 = Dummy
0R	0R = Jumper
XRXX (1 to 9.76 Ω)	1R = 1 Ω 1R5 = 1.5 Ω 9R76 = 9.76 Ω
XXRX (10 to 97.6 Ω)	10R = 10 Ω 97R6 = 97.6 Ω
XXXR (100 to 976 Ω)	100R = 100 Ω
XKXX (1 to 9.76 KΩ)	1K = 1,000 Ω 9K76 = 9760 Ω
XMXX (1 to 9.76 MΩ)	1M = 1,000,000 Ω 9M76 = 9,760,000 Ω

ORDERING EXAMPLE

The ordering code of a RC0201 chip resistor, value 56 Ω with ±1% tolerance, supplied in 7-inch tape reel is: RC0201FR-0756R(L).

NOTE

1. All our RSMD products meet RoHS compliant. "LFP" of the internal 2D reel label mentions "Lead Free Process"
2. On customized label, "LFP" or specific symbol printed and the optional "L" at the end of CTC / I2NC can be added (both are on customer request)

PHYCOMP BRAND ordering codes

Both I2NC (traditional) and Global CTC (preferred) codes are acceptable to order Phycomp brand products.

I2NC CODE

TYPE/ 0201	START IN ⁽¹⁾	TOL. (%)	RESISTANCE RANGE	PAPER / PE TAPE ON REEL (units) ⁽²⁾		
				10,000	20,000	50,000
RC41	2322	±5%	1 to 1 MΩ	803 70xxx	806 80xxx	803 60xxx
RC42	2322	±1%	1 to 1 MΩ	806 7xxxx	806 8xxxx	806 6xxxx
Jumper	2322	-	0 Ω	803 91001	---	---
Dummy	2322	-	-	803 93001	---	---

Resistance decade ⁽³⁾	Last digit
0.01 to 0.0976 Ω	0
0.1 to 0.976 Ω	7
1 to 9.76 Ω	8
10 to 97.6 Ω	9
100 to 976 Ω	1
1 to 9.76 KΩ	2
10 to 97.6 KΩ	3
100 to 976 KΩ	4
1 to 9.76 MΩ	5
10 to 97.6 MΩ	6

- (1) The resistors have a 12-digit ordering code starting with 2322.
- (2) The subsequent 4 or 5 digits indicate the resistor tolerance and packaging.
- (3) The remaining 4 or 3 digits represent the resistance value with the last digit indicating the multiplier as shown in the table of "Last digit of I2NC".
- (4) "L" is optional symbol (Note).

Example:

0.02 Ω	=	0200 or 200
0.3 Ω	=	3007 or 307
1 Ω	=	1008 or 108
33 KΩ	=	3303 or 333
10 MΩ	=	1006 or 106

ORDERING EXAMPLE

The ordering code of a RC42 resistor, value 56 Ω with ±1% tolerance, supplied in tape of 10,000 units per reel is: 232280675609(L) or RC0201FR-0756R(L).

GLOBAL CTC CODE (PREFERRED)

For detailed information of global CTC code and ordering example, please refer to page 2.

NOTE

- 1. All our RSMD products are RoHS compliant. "LFP" of the internal 2D reel label mentions "Lead Free Process"
- 2. On customized label, "LFP" or specific symbol printed and the optional "L" at the end of CTC / I2NC can be added (both are on customer request)

MARKING

RC0201



No marking

For further marking information, please see special data sheet “Chip resistors marking”.

CONSTRUCTION

The resistor is constructed on top of a high-grade ceramic body. Internal metal electrodes are added on each end to make the contacts to the thick film resistive element. The composition of the resistive element is a noble metal imbedded into a glass and covered by a second glass to prevent environment influences. The resistor is laser trimmed to the rated resistance value. The resistor is covered with a protective epoxy coat, finally the two external terminations (matte tin on Ni-barrier) are added. See fig.2

DIMENSIONS

Table I	
TYPE	RC0201
L (mm)	0.60 ±0.03
W (mm)	0.30 ±0.03
H (mm)	0.23 ±0.03
l ₁ (mm)	0.10 ±0.05
l ₂ (mm)	0.15 ±0.05

OUTLINES

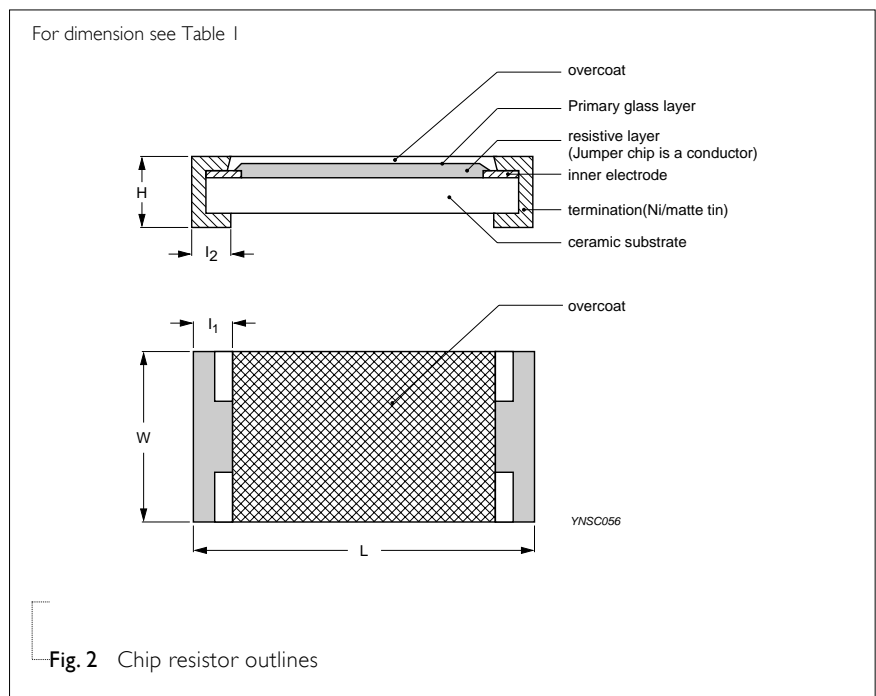

ELECTRICAL CHARACTERISTICS

Table 2

CHARACTERISTICS	RC0201 1/20 W
Operating Temperature Range	-55 °C to +125 °C
Maximum Working Voltage	25 V
Maximum Overload Voltage	50 V
Dielectric Withstanding Voltage	50 V
Resistance Range	5% (E24) 1 Ω to 10 MΩ
	1% (E24/E96) 1 Ω to 1 MΩ
	Zero Ohm Jumper < 0.05 Ω
Temperature Coefficient	1 Ω ≤ R ≤ 10Ω -100/+350 ppm/°C
	10Ω < R ≤ 10 MΩ ±200 ppm/°C
Jumper Criteria	Rated Current 0.5 A
	Maximum Current 1.0 A

FOOTPRINT AND SOLDERING PROFILES

For recommended footprint and soldering profiles, please see the special data sheet “Chip resistors mounting”.

PACKING STYLE AND PACKAGING QUANTITY

Table 3 Packing style and packaging quantity

PRODUCT TYPE	PACKING STYLE	REEL DIMENSION	QUANTITY PER REEL
RC0201	Paper Taping Reel (R)	7" (178 mm)	10,000 units
		10" (254 mm)	20,000 units
		13" (330 mm)	50,000 units

NOTE

1. For Paper tape and reel specification/dimensions, please see the special data sheet “Packing” document.

FUNCTIONAL DESCRIPTION

POWER RATING

RC0201 rated power at 70°C is 1/20 W

RATED VOLTAGE

The DC or AC (rms) continuous working voltage corresponding to the rated power is determined by the following formula:

$$V = \sqrt{P \times R}$$

or max. working voltage whichever is less

Where

V=Continuous rated DC or AC (rms) working voltage (V)

P=Rated power (W)

R=Resistance value (Ω)

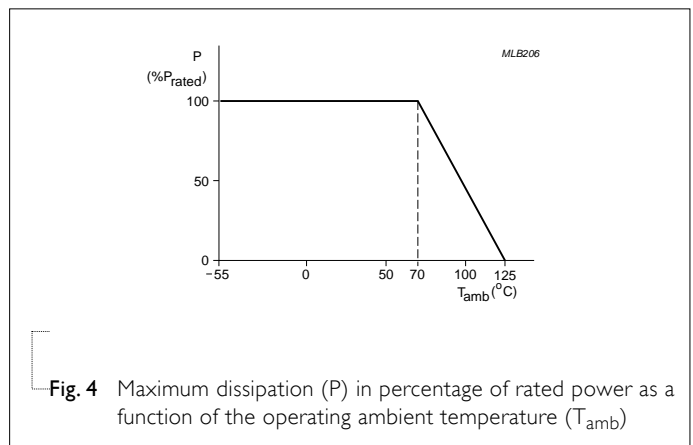

TESTS AND REQUIREMENTS
Table 4 Test condition, procedure and requirements

TEST	TEST METHOD	PROCEDURE	REQUIREMENTS
Life/ Operational Life/ Endurance	MIL-STD-202G-method 108A	1,000 hours at 70±5 °C applied RCWV	±(2%+0.05 Ω)
	IEC 60115-1 4.25.1	1.5 hours on, 0.5 hour off, still air required	<100 mΩ for Jumper
	JIS C 5202-7.10		
High Temperature Exposure/ Endurance at upper category temperature	MIL-STD-202G-method 108A	1,000 hours at maximum operating temperature	±(1%+0.05 Ω)
	IEC 60115-1 4.25.3	depending on specification, unpowered	<50 mΩ for Jumper
	JIS C 5202-7.11	No direct impingement of forced air to the parts Tolerances: 125±3 °C	
Moisture Resistance	MIL-STD-202G-method 106F	Each temperature / humidity cycle is defined at 8	±(2%+0.05 Ω)
	IEC 60115-1 4.24.2	hours (method 106F), 3 cycles / 24 hours for 10d	<100 mΩ for Jumper
		with 25 °C / 65 °C 95% R.H, without steps 7a & 7b, unpowered Parts mounted on test-boards, without condensation on parts Measurement at 24±2 hours after test conclusion	
Thermal Shock	MIL-STD-202G-method 107G	-55/+125 °C	±(0.5%+0.05Ω) for 10 KΩ to
		Note: Number of cycles required is 300. Devices	10 MΩ
		unmounted	±(1%+0.05Ω) for others
		Maximum transfer time is 20 seconds. Dwell time	<50 mΩ for Jumper
		is 15 minutes. Air – Air	
Short time overload	MIL-R-55342D-para 4.7.5	2.5 times RCWV or maximum overload voltage	±(2%+0.05Ω)
	IEC60115-1 4.13	whichever is less for 5 sec at room temperature	<50mΩ for Jumper No visible damage
Board Flex/ Bending	IEC60115-1 4.33	Device mounted on PCBoard as described, only	±(1%+0.05Ω)
		1 board bending required	<50mΩ for Jumper
		3 mm bending	No visible damage
		Bending time: 60±5 seconds	
		Ohmic value checked during bending	

TEST	TEST METHOD	PROCEDURE	REQUIREMENTS
Solderability - Wetting	IPC/JEDECJ-STD-002B test B IEC 60068-2-58	Electrical Test not required. Magnification 50X. SMD conditions: 1 st step: method B, aging 4 hours at 155°C dry heat 2 nd step: leadfree solder bath at 245±3°C Dipping time: 3±0.5 seconds	Well tinned (≥95% covered) No visible damage
- Leaching	IPC/JEDECJ-STD-002B test D IEC 60068-2-58	Leadfree solder, 260 °C, 30 seconds immersion time	No visible damage
- Resistance to Soldering Heat	MIL-STD-202G-method 210F IEC 60068-2-58	Condition B, no pre-heat of samples. Leadfree solder, 270 °C, 10 seconds immersion time Procedure 2 for SMD: devices fluxed and cleaned with isopropanol	±(1%+0.05Ω) <50mΩ for Jumper No visible damage

REVISION HISTORY

REVISION	DATE	CHANGE NOTIFICATION	DESCRIPTION
Version 3	Apr 25, 2007	-	<ul style="list-style-type: none"> - New datasheet for 0201 thick film 1% and 5% with lead-free terminations - Replace the 0201 part of pdf files: Pu-RC0201_5I_PbFree_L_2 and Yu-RC0201_5I_PbFree_L_2 - Max. working voltage, resistance rage, and TCR updated - Tests and Requirements updated
Version 2	Sep 03, 2004	-	<ul style="list-style-type: none"> - New datasheet for 0201 thick film 1% and 5% with lead-free terminations - Replace the 0201 part of pdf files: RC41_5_4, RC42_1_1 - Test method and procedure updated - PE tape added (paper tape will be replaced by PE tape)

“Yageo reserves all the rights for revising the content of this datasheet without further notification, as long as the products itself are unchanged. Any product change will be announced by PCN.”