

LM7372

LM7372 High Speed, High Output Current, Dual Operational Amplifier



Literature Number: SNOS926D

LM7372

High Speed, High Output Current, Dual Operational Amplifier

General Description

The LM7372 is a high speed dual voltage feedback amplifier that has the slewing characteristic of current feedback amplifiers; yet it can be used in all traditional voltage feedback amplifier configurations.

The LM7372 is stable for gains as low as +2 or -1. It provides a very high slew rate at 3000V/ μ s and a wide gain bandwidth product of 120MHz, while consuming only 6.5mA/per amplifier of supply current. It is ideal for video and high speed signal processing applications such as xDSL and pulse amplifiers. With 150mA output current, the LM7372 can be used for video distribution, as a transformer driver or as a laser diode driver.

Operation on \pm 15V power supplies allows for large signal swings and provides greater dynamic range and signal-to-noise ratio. The LM7372 offers high SFDR and low THD, ideal for ADC/DAC systems. In addition, the LM7372 is specified for \pm 5V operation for portable applications.

The LM7372 is built on National's Advance VIP[®] III (Vertically integrated PNP) complementary bipolar process.

Features

- -80dBc highest harmonic distortion @ 1MHz, 2V_{PP}
- Very high slew rate: 3000V/ μ s
- Wide gain bandwidth product: 120MHz
- -3dB frequency @ A_V = +2: 200MHz
- Low supply current: 13mA (both amplifiers)
- High open loop gain: 85dB
- High output current: 150mA
- Differential gain and phase: 0.01%, 0.02°

Applications

- HDSL and ADSL Drivers
- Multimedia broadcast systems
- Professional video cameras
- CATV/Fiber optics signal processing
- Pulse amplifiers and peak detectors
- HDTV amplifiers

Typical Application

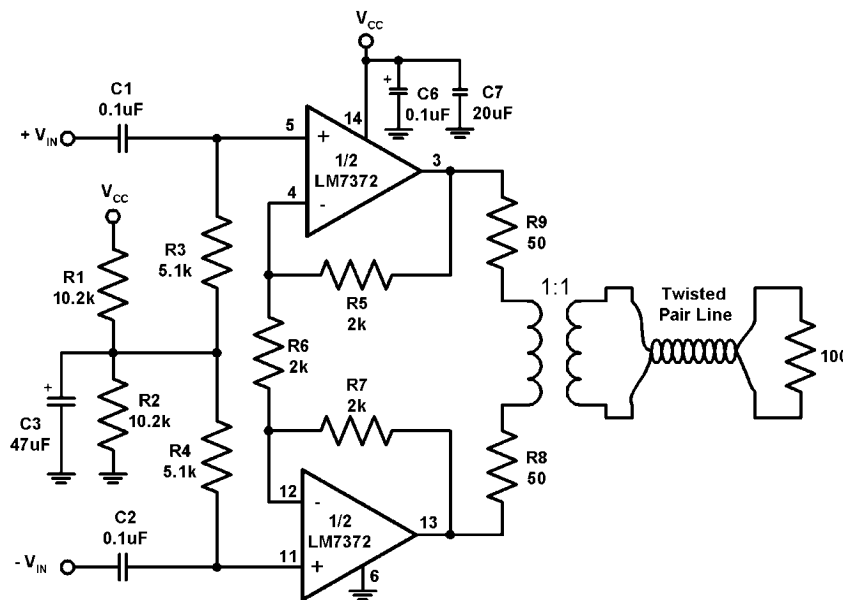

20004903

FIGURE 1. Single Supply Application (16-Pin SOIC)

Connection Diagrams

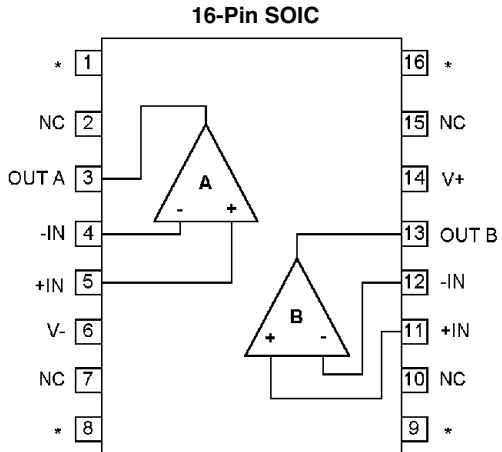

20004902

* Heatsink Pins. See note 4

Top View

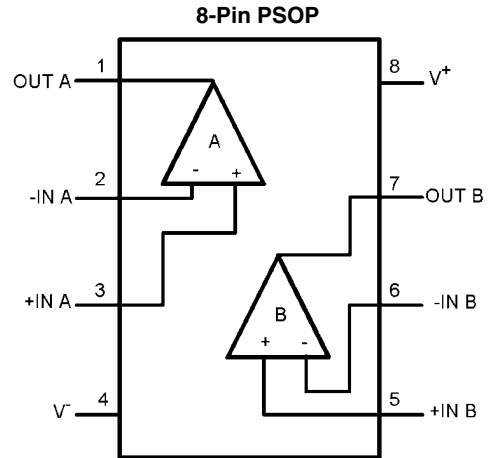

20004929

Top View

Note: For PSOP and SOIC the exposed pad should be tied either to V- or left electrically floating.
(Die attach material is conductive and is internally tied to V-)

Ordering Information

Symbol	Temperature Range	Package Marking	Transport Media	NSC Drawing
	-40°C to 85°C			
16-Pin SOIC	LM7372IMA	LM7372IMA	48 Units/Rail	M16A
	LM7372IMAX		2.5k Units Tape and Reel	
8-Pin PSOP	LM7372MR	LM7372MR	95 Units/Rail	MRA08B
	LM7372MRX		2.5k Units Tape and Reel	

Absolute Maximum Ratings (Notes 1, 3)

If Military/Aerospace specified devices are required, please contact the National Semiconductor Sales Office/Distributors for availability and specifications.

ESD Tolerance

Human Body Model	1.5kV (Note 2)
Machine Model	200V (Note 2)
Supply Voltage (V+–V–)	36V
Differential Input Voltage ($V_S = \pm 15V$)	$\pm 10V$
Output Short Circuit to Ground (Note 3)	Continuous
Storage Temp. Range	$-65^\circ C$ to $150^\circ C$
Soldering Information	
Infrared or Convection Reflow (20 sec.)	$235^\circ C$
Wave Soldering Lead Temperature (10 sec.)	$260^\circ C$

Input Voltage	V– to V+
Maximum Junction Temperature (Note 4)	$150^\circ C$

Operating Ratings (Note 1)

Supply Voltage	$9V \leq V_S \leq 36V$
Junction Temperature Range (T_J)	
LM7372	$-40^\circ C \leq T_J \leq 85^\circ C$
Thermal Resistance(θ_{JA})	
16-Pin SOIC see (Note 4)	$106^\circ C/W$ $70^\circ C/W$
8-Pin PSOP (Note 4) (see Application Information)	$47^\circ C/W$

 $\pm 15V$ DC Electrical Characteristics

Unless otherwise specified, all limits guaranteed for $T_J = 25^\circ C$, $V_{CM} = 0V$ and $R_L = 1k\Omega$. **Boldface** apply at the temperature extremes.

Symbol	Parameter	Conditions	Min (Note 6)	Typ (Note 5)	Max (Note 6)	Units
V_{OS}	Input Offset Voltage			2.0	8.0 10.0	mV
TC V_{OS}	Input Offset Voltage Average Drift			12		$\mu V/^\circ C$
I_B	Input Bias Current			2.7	10 12	μA
I_{OS}	Input Offset Current			0.1	4.0 6.0	μA
R_{IN}	Input Resistance	Common Mode		40		$M\Omega$
		Differential Mode		3.3		$M\Omega$
R_O	Open Loop Output Resistance			15		Ω
CMRR	Common Mode Rejection Ratio	$V_{CM} = \pm 10V$	75 70	93		dB
PSRR	Power Supply Rejection Ratio	$V_S = \pm 15V$ to $\pm 5V$	75 70	90		dB
V_{CM}	Input Common-Mode Voltage Range	CMRR > 60dB		± 13		V
A_V	Large Signal Voltage Gain (Note 7)	$R_L = 1k\Omega$	75 70	85		dB
		$R_L = 100\Omega$	70 66	81		dB
V_O	Output Swing	$R_L = 1k\Omega$	13 12.7	13.4		V
			-13 -12.7	-13.3		V
		$I_{OUT} = -150mA$	11.8 11.4	12.4		V
		$I_{OUT} = 150mA$	-11.2 -10.8	-11.9		V
I_{SC}	Output Short Circuit Current	Sourcing		260		mA
		Sinking		250		mA
I_S	Supply Current (both Amps)			13	17 19	mA

±15V AC Electrical Characteristics

Unless otherwise specified, all limits guaranteed for $T_J = 25^\circ\text{C}$, $V_{CM} = 0\text{V}$ and $R_L = 1\text{k}\Omega$. **Boldface** apply at the temperature extremes.

Symbol	Parameter	Conditions	Min (Note 6)	Typ (Note 5)	Max (Note 6)	Units
SR	Slew Rate (Note 8)	$A_V = +2$, $V_{IN} = 13V_{P-P}$		3000		V/ μs
		$A_V = +2$, $V_{IN} = 10V_{P-P}$		2000		
	Unity Bandwidth Product			120		MHz
	-3dB Frequency	$A_V = +2$		220		MHz
ϕ_m	Phase Margin	$A_{VOL} = 6\text{dB}$		70		deg
t_s	Settling Time (0.1%)	$A_V = -1$, $A_O = \pm 5\text{V}$, $R_L = 500\Omega$		50		ns
t_p	Propagation Delay	$A_V = -2$, $V_{IN} = \pm 5\text{V}$, $R_L = 500\Omega$		6.0		ns
A_D	Differential Gain (Note 9)			0.01		%
ϕ_D	Differential Phase (Note 9)			0.02		deg
hd2	Second Harmonic Distortion $F_{IN} = 1\text{MHz}$, $A_V = +2$	$V_{OUT} = 2V_{P-P}$, $R_L = 100\Omega$		-80		dBc
		$V_{OUT} = 16.8V_{P-P}$, $R_L = 100\Omega$		-73		
hd3	Third Harmonic Distortion $F_{IN} = 1\text{MHz}$, $A_V = +2$	$V_{OUT} = 2V_{P-P}$, $R_L = 100\Omega$		-91		dBc
		$V_{OUT} = 16.8V_{P-P}$, $R_L = 100\Omega$		-67		
IMD	Intermodulation Distortion	$F_{in 1} = 75\text{kHz}$, $F_{in 2} = 85\text{kHz}$ $V_{OUT} = 16.8V_{P-P}$, $R_L = 100\Omega$		-87		dBc
e_n	Input-Referred Voltage Noise	$f = 10\text{kHz}$		14		nV/ $\sqrt{\text{Hz}}$
i_n	Input-Referred Current Noise	$f = 10\text{kHz}$		1.5		pA/ $\sqrt{\text{Hz}}$

±5V DC Electrical Characteristics

Unless otherwise specified, all limits guaranteed for $T_J = 25^\circ\text{C}$, $V_{CM} = 0\text{V}$ and $R_L = 1\text{k}\Omega$. **Boldface** apply at the temperature extremes.

Symbol	Parameter	Conditions	Min (Note 6)	Typ (Note 5)	Max (Note 6)	Units
V_{OS}	Input Offset Voltage			2.2	8.0 10.0	mV
TC V_{OS}	Input Offset Voltage Average Drift			12		$\mu\text{V}/^\circ\text{C}$
I_B	Input Bias Current			3.3	10 12	μA
I_{OS}	Input Offset Current			0.1	4 6	μA
R_{IN}	Input Resistance	Common Mode		40		M Ω
		Differential Mode		3.3		M Ω
R_O	Open Loop Output Resistance			15		Ω
CMRR	Common Mode Rejection Ratio	$V_{CM} = \pm 2.5\text{V}$	70 65	90		dB
PSRR	Power Supply Rejection Ratio	$V_S = \pm 15\text{V}$ to $\pm 5\text{V}$	75 70	90		dB
V_{CM}	Input Common-Mode Voltage Range	CMRR > 60dB		± 3		V
A_V	Large Signal Voltage Gain (Note 7)	$R_L = 1\text{k}\Omega$	70 65	78		dB
		$R_L = 100\Omega$	64 60	72		dB

Symbol	Parameter	Conditions	Min (Note 6)	Typ (Note 5)	Max (Note 6)	Units
V_O	Output Swing	$R_L = 1k\Omega$	3.2 3.0	3.4		V
			-3.2 -3.0	-3.4		V
		$I_{OUT} = -80mA$	2.5 2.2	2.8		V
		$I_{OUT} = 80mA$	-2.5 -2.2	-2.7		V
I_{SC}	Output Short Circuit Current	Sourcing		150		mA
		Sinking		150		mA
I_S	Supply Current (both Amps)			12.4	16 18	mA

±5V AC Electrical Characteristics

Unless otherwise specified, all limits guaranteed for $T_J = 25^\circ C$, $V_{CM} = 0V$ and $R_L = 1k\Omega$. **Boldface** apply at the temperature extremes.

Symbol	Parameter	Conditions	Min (Note 6)	Typ (Note 5)	Max (Note 6)	Units
SR	Slew Rate (Note 8)	$A_V = +2$, $V_{IN} = 3V_{P-P}$		700		V/ μs
	Unity Bandwidth Product			100		MHz
	-3dB Frequency	$A_V = +2$		125		MHz
ϕ_m	Phase Margin			70		deg
t_S	Settling Time (0.1%)	$A_V = -1$, $V_O = \pm 1V$, $R_L = 500\Omega$		70		ns
t_P	Propagation Delay	$A_V = +2$, $V_{IN} = \pm 1V$, $R_L = 500\Omega$		7		ns
A_D	Differential Gain (Note 9)			0.02		%
ϕ_D	Differential Phase (Note 9)			0.03		deg
hd2	Second Harmonic Distortion $F_{IN} = 1MHz$, $A_V = +2$	$V_{OUT} = 2V_{P-P}$, $R_L = 100\Omega$		-84		dBc
hd3	Third Harmonic Distortion $F_{IN} = 1MHz$, $A_V = +2$	$V_{OUT} = 2V_{P-P}$, $R_L = 100\Omega$		-94		dBc
e_n	Input-Referred Voltage Noise	$f = 10kHz$		14		nV/\sqrt{Hz}
i_n	Input-Referred Current Noise	$f = 10kHz$		1.8		pA/\sqrt{Hz}

Note 1: Absolute Maximum Ratings indicate limits beyond which damage to the device may occur. Operating Ratings indicate conditions for which the device is intended to be functional, but specific performance is not guaranteed. For guaranteed specifications and the test conditions, see the Electrical Characteristics.

Note 2: For testing purposes, ESD was applied using human body model, 1.5k Ω in series with 100pF. Machine model, 0 Ω in series with 200pF.

Note 3: Applies to both single-supply and split-supply operation. Continuous short circuit operation at elevated ambient temperature can result in exceeding the maximum allowed junction temperature of 150°C.

Note 4: The maximum power dissipation is a function of $T_{(JMAX)}$, θ_{JA} , and T_A . The maximum allowable power dissipation at any ambient temperature is $P_D = (T_{(JMAX)} - T_A)/\theta_{JA}$. All numbers apply for packages soldered directly into a PC board. The value for θ_{JA} is 106°C/W for the 16-Pin SOIC package. With a total area of 4sq. in of 1oz CU connected to pins 1,6,8,9 & 16, θ_{JA} for the 16-Pin SOIC is decreased to 70°C/W. 8-Pin PSOP package θ_{JA} is with 2 in² heatsink (top and bottom layer each) and 1 oz. copper (see Table 2).

Note 5: Typical values represent the most likely parametric norm.

Note 6: All limits are guaranteed by testing or statistical analysis.

Note 7: Large signal voltage gain is the total output swing divided by the input signal required to produce that swing. For $V_S = \pm 15V$, $V_{OUT} = \pm 10V$. For $V_S = \pm 5V$, $V_{OUT} = \pm 2V$

Note 8: Slew Rate is the average of the rising and falling slew rates.

Note 9: Differential gain and phase are measured with $A_V = +2$, $V_{IN} = 1V_{PP}$ at 3.58 MHz and output is 150 Ω terminated.

Typical Performance Characteristics

Harmonic Distortion vs. Frequency

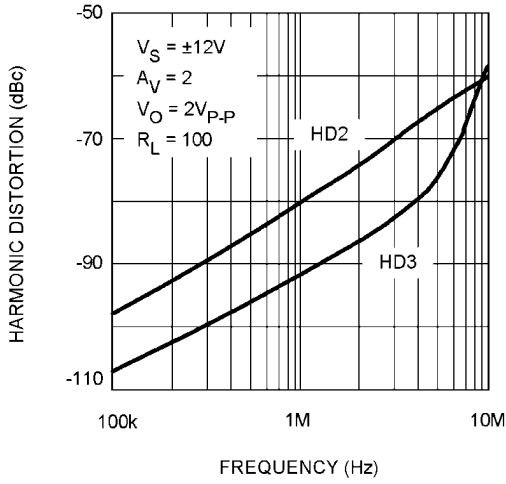

Harmonic Distortion vs. Frequency

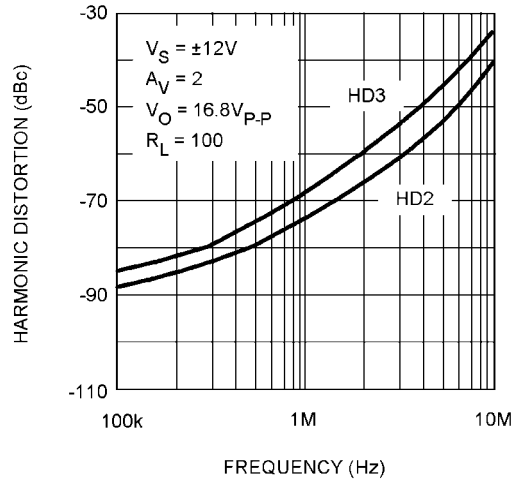

Harmonic Distortion vs. Frequency

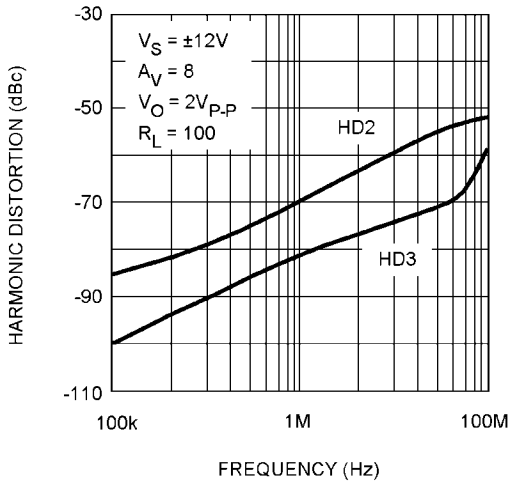

Harmonic Distortion vs. Frequency

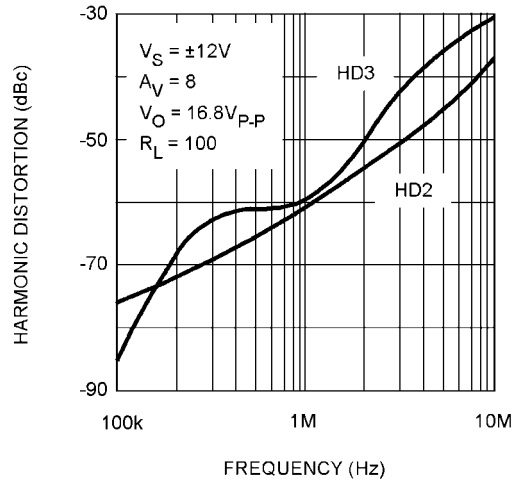

Harmonic Distortion vs. Output Level

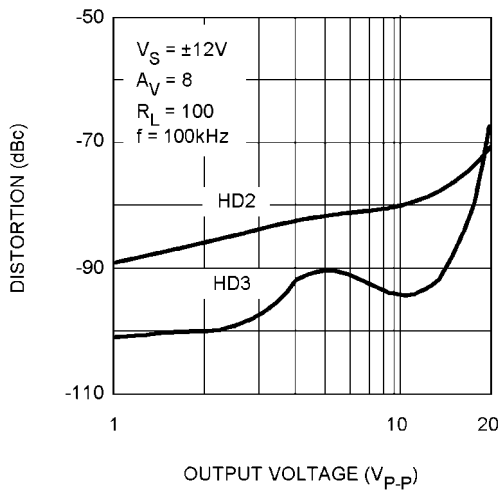

Harmonic Distortion vs. Output Level

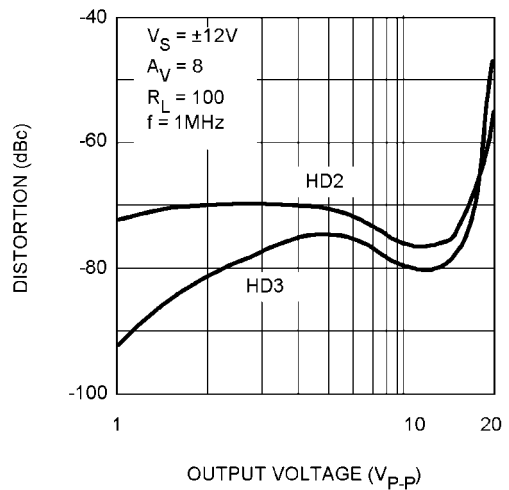

Harmonic Distortion vs. Output Level

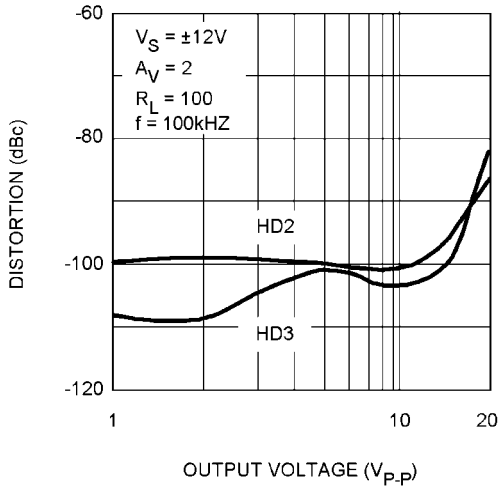

20004910

Harmonic Distortion vs. Output Level

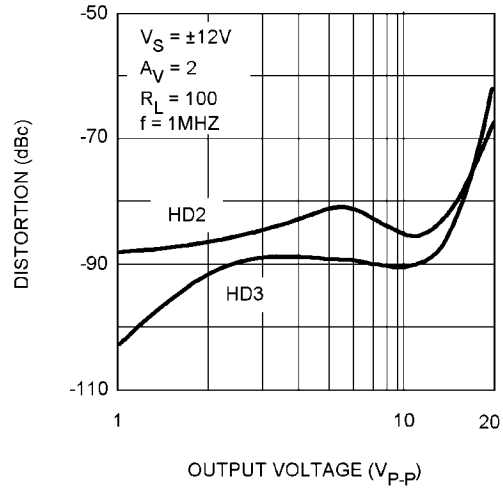

20004911

Harmonic Distortion vs. Load Resistance

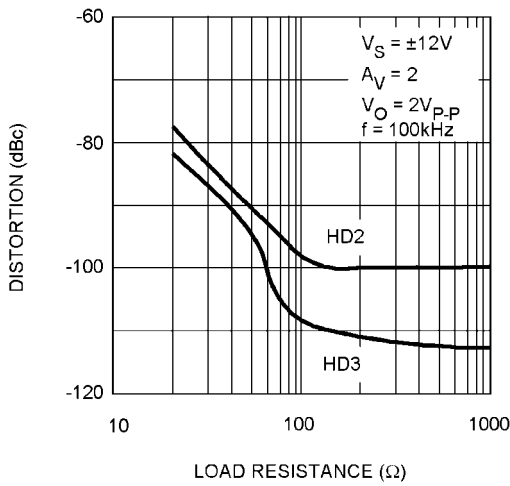

20004912

Harmonic Distortion vs. Load Resistance

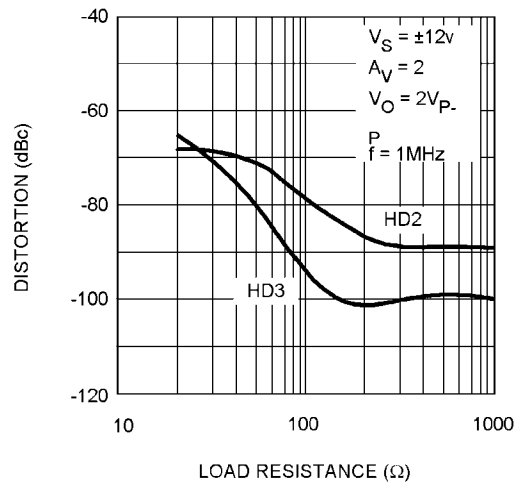

20004913

Harmonic Distortion vs. Load Resistance

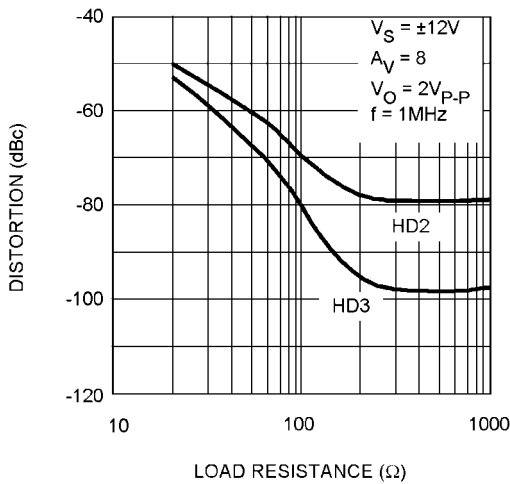

20004914

Harmonic Distortion vs. Load Resistance

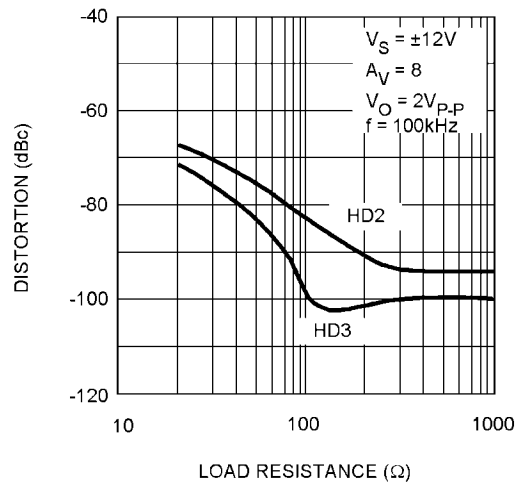

20004915

Frequency Response

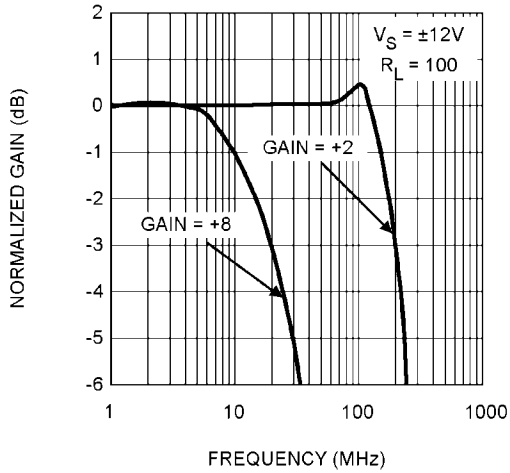

20004916

Frequency Response

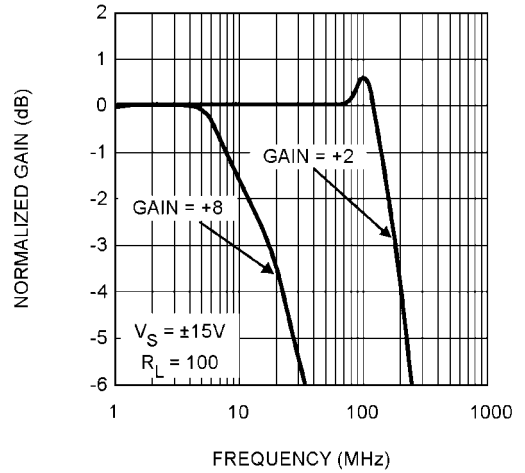

20004917

Frequency Response

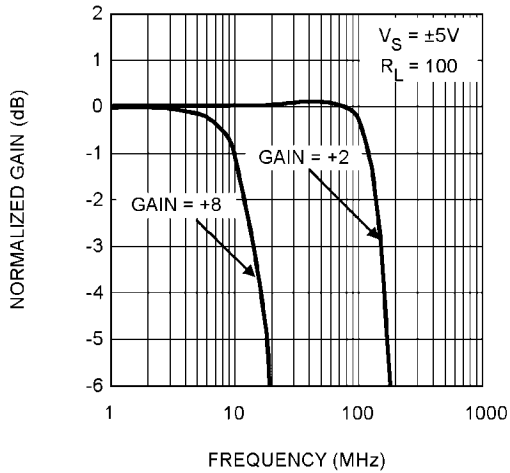

20004918

Small Signal Pulse Response

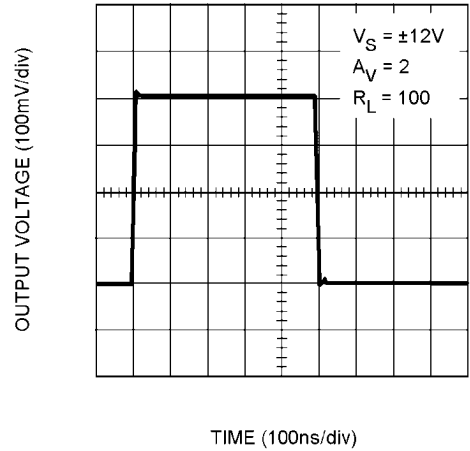

20004920

Large Signal Pulse Response

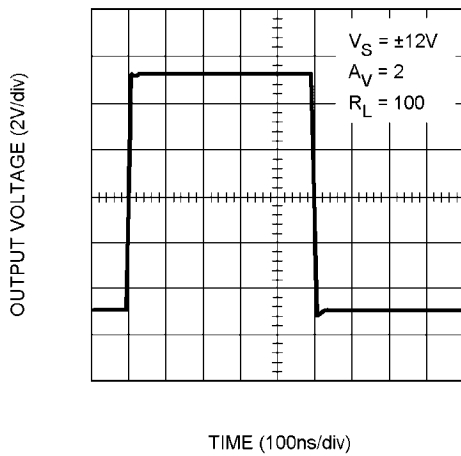

20004921

Thermal Performance of 8ld-PSOP

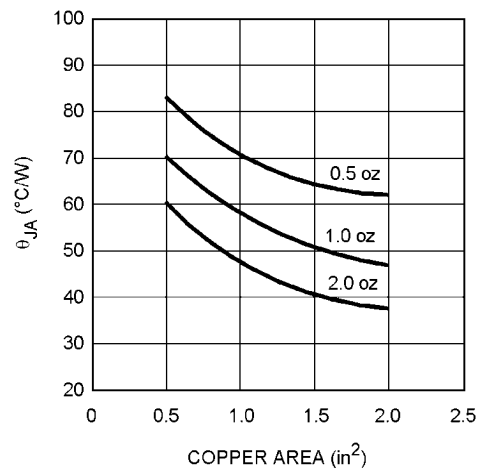

20004922

Harmonic Distortion vs. Frequency

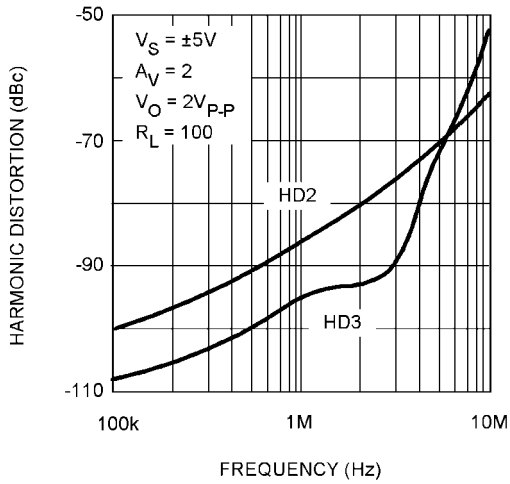

20004927

Input Bias Current (μA) vs. Temperature

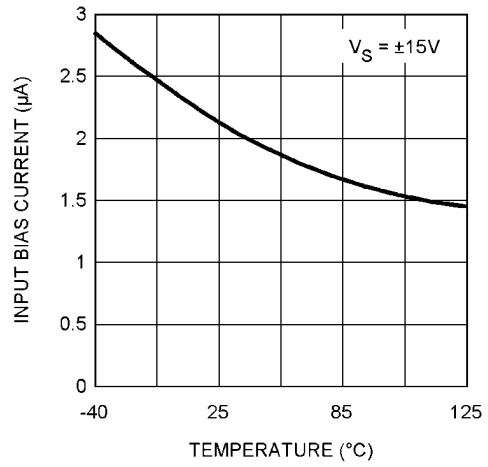

20004923

Output Voltage vs. Output Current

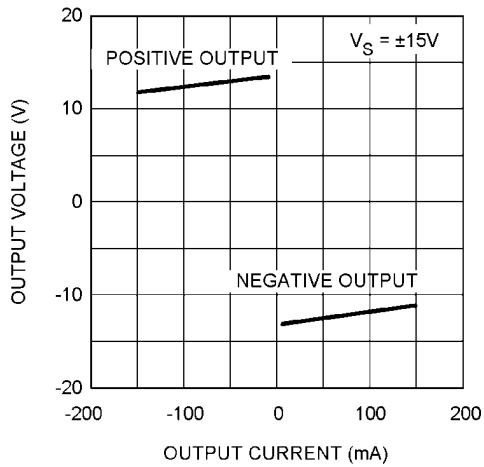

20004924

Simplified Schematic Diagram

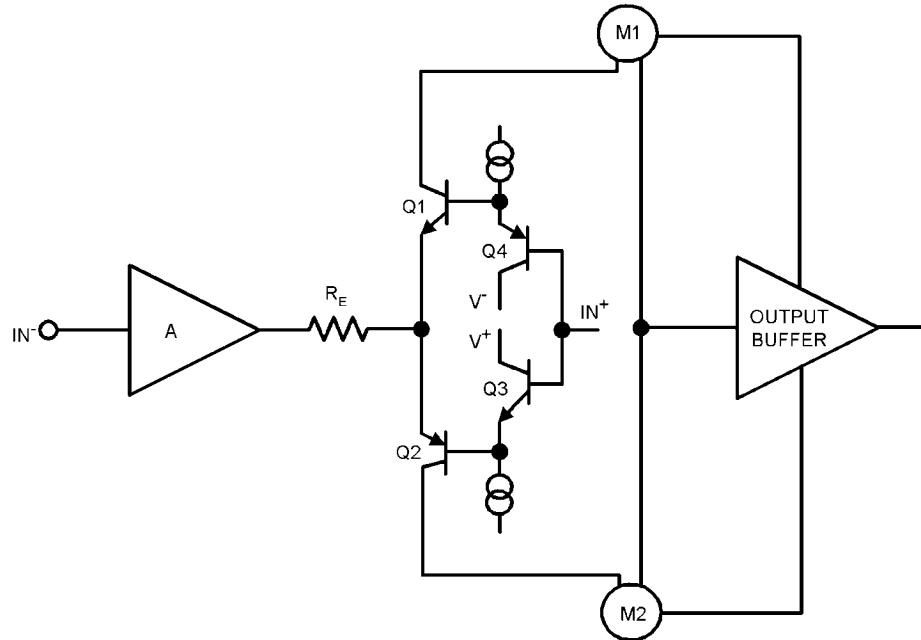

20004928

Application Information

The LM7372 is a high speed dual operational amplifier with a very high slew rate and very low distortion, yet like many other op amps, it is used in conventional voltage feedback amplifier applications. Also, again like many op amps, it has a class AB output stage in order to be able to deliver high currents to low impedance loads, yet draw a low quiescent supply current in most situations (the supply current increases when necessary to keep up with large output swing and/or high frequency. See "High Frequency/Large Signal Swing Considerations" section below). For most op amps in typical applications, this topology means that internal power dissipation is rarely an issue, even with the trend to smaller surface mount packages. However, the LM7372 has been designed for applications where significant levels of power dissipation will be encountered, and an effective means of removing the internal heat generated by this power dissipation is needed to maintain the semiconductor junction temperature at acceptable levels, particularly in environments with elevated ambient temperatures.

Several factors contribute to power dissipation and consequently higher semiconductor junction temperatures, and these factors need to be well understood if the LM7372 is to perform to the desired specifications in a given application. Since different applications will have different dissipation levels and different compromises can be made between the ways these factors will contribute to the total junction temperature, this section will examine the typical application shown on the front page of this data sheet as an example, and offer suggestions for solutions where excessive junction temperatures are encountered.

There are two major contributors to the internal power dissipation; the product of the supply voltage and the LM7372 quiescent current when no signal is being delivered to the external load, and the additional power dissipated while delivering power to the external load. For low frequency (<1MHz) applications, the LM7372 supply current specification will suf-

fice to come up with the quiescent power dissipation (see "High Frequency/Large Signal Swing Considerations" section for cases where the frequency range exceeds 1MHz and the LM7372 supply current increases). The LM7372 quiescent supply current is given as 6.5mA per amplifier, so with a 24-Volt supply the power dissipation is

$$\begin{aligned} P_Q &= V_S \times 2I_q \quad (V_S = V^+ - V^-) \\ &= 24 \times 2 \times (6.5 \times 10^{-3}) \\ &= 312\text{mW} \end{aligned}$$

This is already a high level of internal power dissipation, and in a small surface mount package with a thermal resistance ($\theta_{JA} = 140^\circ\text{C}/\text{Watt}$ (a not unreasonable value for an 8-Pin SOIC package) would result in a junction temperature $140^\circ\text{C}/\text{W} \times 0.312\text{W} = 43.7^\circ\text{C}$ above the ambient temperature. A similar calculation using the worst case maximum supply current specification of 8.5mA per amplifier at an 85°C ambient will yield a power dissipation of 456mW with a junction temperature of 149°C , perilously close to the maximum permitted junction temperature of 150°C !

The second contributor to high junction temperature is the additional power dissipated internally when power is being delivered to the external load. This cause of temperature rise can be less amenable to calculation, even when the actual operating conditions are known.

For a Class B output stage, one transistor of the output pair will conduct the load current as the output voltage swings positive, with the other transistor drawing no current, and hence dissipating no power. During the other half of the signal swing this situation is reversed, with the lower transistor sinking the load current and the upper transistor is cut off. The current in each transistor will be a half wave rectified version of the total load current. Ideally neither transistor will dissipate power when there is no signal swing, but will dissipate increasing power as the output current increases. However, as

the signal voltage across the load increases with load current, the voltage across the output transistor (which is the difference voltage between the supply voltage and the instantaneous voltage across the load) will decrease and a point will be reached where the dissipation in the transistor will begin to decrease again. If the signal is driven into a square wave, ideally the transistor dissipation will fall all the way back to zero.

For each amplifier then, with an effective load each of R_L and a sine wave source, integration over the half cycle with a supply voltage V_S and a load voltage V_L yields the average power dissipation

$$P_D = V_S V_L / \pi R_L - V_L^2 / 2 R_L \dots \dots (1)$$

Where V_S is the supply voltage and V_L is the peak signal swing across the load R_L .

For the package, the power dissipation will be doubled since there are two amplifiers in the package, each contributing half the swing across the load.

The circuit in *Figure 1* is using the LM7372 as the upstream driver in an ADSL application with Discrete MultiTone modulation. With DMT the upstream signal is spread into 32 adjacent channels each 4kHz wide. For transmission over POTS, the regular telephone service, this upstream signal from the CPE (Customer Premise Equipment) occupies a frequency band from around 20kHz up to a maximum frequency of 135kHz. At first sight, these relatively low transmission frequencies certainly do not seem to require the use of very high speed amplifiers with GBW products in the range of hundreds of megahertz. However, the close spacing of multiple channels places stringent requirements on the linearity of the amplifier, since non-linearities in the presence of multiple tones will cause harmonic products to be generated that can easily interfere with the higher frequency down stream signals also present on the line. The need to deliver 3rd Harmonic distortion terms lower than -75dBc is the reason for the LM7372 quiescent current levels. Each amplifier is running over 3mA in the output stage alone in order to minimize crossover distortion.

xDSL signal levels are adjusted to provide a given power level on the line, and in the case of ADSL this is an average power of 13dBm. For a line with a characteristic impedance of 100Ω this is only 20mW ($= 1\text{mW} \times 10^{(13/10)}$). Because the transformer shown in *Figure 1* is part of a transceiver circuit, two back-termination resistors are connected in series with each amplifier output. Therefore the equivalent R_L for each amplifier is also 100Ω , and each amplifier is required to deliver 20mW to this load.

$$\text{Since } V_L^2 / 2R_L = 20\text{mW then } V_L = 2\text{V(peak)}.$$

Using Equation (1) with this value for signal swing and a 24V supply, the internal power dissipation per amplifier is 132.8mW. Adding the quiescent power dissipation to the amplifier dissipation gives the total package internal power dissipation as

$$P_{D(\text{TOTAL})} = 312\text{mW} + (2 \times 132.8\text{mW}) = 578\text{mW}$$

This result is actually quite pessimistic because it assumes that the dissipation as a result of load current is simply added to the dissipation as a result of quiescent current. This is not correct since the AB bias current in the output stage is diverted to load current as the signal swing amplitude increases from zero. In fact with load currents in excess of 3.3mA, all the bias current is flowing in the load, consequently reducing the quiescent component of power dissipation. Also, it assumes a sine wave signal waveform when the actual waveform is composed of many tones of different phases and

amplitudes which may demonstrate lower average power dissipation levels.

The average current for a load power of 20mW is 14.1mA ($= \sqrt{(20\text{mW}/100)}$). Neglecting the AB bias current, this appears as a full-wave rectified current waveform in the supply current with a peak value of 19.9mA. The peak to average ratio for a waveform of this shape is 1.57, so the total average load current is 12.7mA ($= 19.9\text{mA}/1.57$). Adding this to the quiescent current, and subtracting the power dissipated in the load ($20\text{mV} \times 2 = 40\text{mW}$) gives the same package power dissipation level calculated above ($= (12.7 + 13) \text{mA} \times 24\text{V} - 40\text{mW} = 576 \text{mW}$). Nevertheless, when the supply current peak swing is measured, it is found to be significantly lower because the AB bias current is contributing to the load current. The supply current has a peak swing of only 14mA (compared to 19.9mA) superimposed on the quiescent current, with a total average value of only 21mA. Therefore the total package power dissipation in this application is

$$\begin{aligned} P_{D(\text{TOTAL})} &= (V_S \times I_{\text{avg}}) - \text{Power in Load} \\ &= (24 \times 21)\text{mW} - 40\text{mW} \\ &= 464\text{mW} \end{aligned}$$

This level of power dissipation would not take the junction temperature in the 8-Pin SOIC package over the absolute maximum rating at elevated ambient temperatures (barely), but there is no margin to allow for component tolerances or signal variances.

To develop 20mW in a 100Ω requires each amplifier to deliver a peak voltage of only 2V, or $4V_{(p-p)}$. This level of signal swing does not require a high supply voltage but the application uses a 24V supply. This is because the modulation technique uses a large number of tones to transmit the data. While the average power level is held to 20mW, at any time the phase and amplitude of individual tones will be such as to generate a combined signal with a higher peak value than 2V. For DMT this crest factor is taken to be around 5.33 so each amplifier has to be able to handle a peak voltage swing of

$$V_{L\text{peak}} = 1.4 \times 5.33 = 7.5\text{V or } 15V_{(p-p)}$$

If other factors, such as transformer loss or even higher peak to average ratios are allowed for, this means the amplifiers must each swing between 16 to $18V_{(p-p)}$.

The required signal swing can be reduced by using a step-up transformer to drive the line. For example a 1:2 ratio will reduce the peak swing requirement by half, and this would allow the supply to be reduced by a corresponding amount. This is not recommended for the LM7372 in this particular application for two reasons. Although the quiescent power contribution to the overall dissipation is reduced by about 150mW, the internal power dissipation to drive the load remains the same, since the load for each amplifier is now 25Ω instead of 100Ω . Furthermore, this is a transceiver application where downstream signals are simultaneously appearing at the transformer secondary. The down stream signals appear differentially across the back termination resistors and are now stepped down by the transformer turns ratio with a consequent loss in receiver sensitivity compared to using a 1:1 transformer. Any trade-off to reduce the supply voltage by an increase in turns ratio should bear these factors in mind, as well as the increased signal current levels required with lower impedance loads.

At an elevated ambient temperature of 85°C and with an average power dissipation of 464mW, a package thermal resistance between 60°C/W and 80°C/W will be needed to keep the maximum junction temperature in the range 110°C to 120°C . The PSOP package would be the package of choice

here with ample board copper area to aid in heat dissipation (see table 2).

For most standard surface mount packages, 8-Pin SOIC, 14-Pin SOIC, 16-Pin SOIC etc, the only means of heat removal from the die is through the bond wires to external copper connecting to the leads. Usually it will be difficult to reduce the thermal resistance of these packages below 100°C/W by these methods and several manufacturers, including National, offer package modifications to enhance the thermal characteristics.

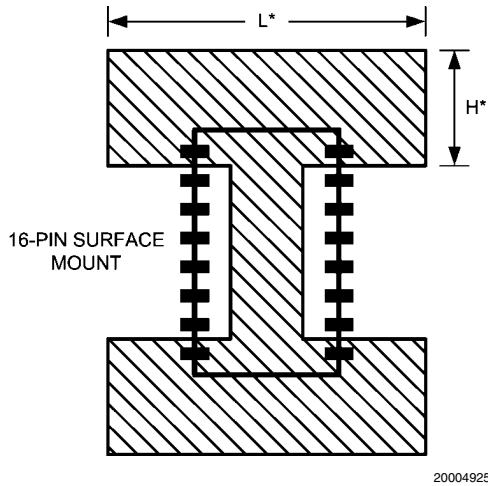

FIGURE 2. Copper Heatsink Patterns

The LM7372 is available in the 16-Pin SOIC package. Since only 8 pins are needed for the two operational amplifiers, the remaining pins are used for heat sink purposes. Each of the end pins, 1,8,9 & 16 are internally bonded to the lead frame and form an effective means of transferring heat to external copper. This external copper can be either electrically isolated or be part of the topside ground plane in a single supply application.

Figure 2. shows a copper pattern which can be used to dissipate internal heat from the LM7372. Table 1 gives some values of θ_{JA} for different values of L and H with 1oz copper.

TABLE 1. 16-Pin SOIC Thermal Resistance with Area of Cu

L (in)	H (in)	θ_{JA} (°C/W)
1	0.5	83
2	1	70
3	1.5	67

From Table 1 it is apparent that two areas of 1oz copper at each end of the package, each 2 in² in area (for a total of 2600mm²) will be sufficient to hold the maximum junction temperature under 120°C with an 85°C ambient temperature.

An even better package for removing internally generated heat is a package with an exposed die attach paddle. Improved removal of internal heat can be achieved by directly connecting bond wires to the lead frame inside the package. Since this lead frame supports the die attach paddle, heat is transferred directly from the substrate to the outside copper by these bond wires. The LM7372 is also available in the 8-Pin PSOP package. For this package the entire lower surface of the paddle is not covered with plastic, which would otherwise act as a thermal barrier to heat transfer. Heat is transferred directly from the die through the paddle rather than

through the small diameter bonding wires. Values of θ_{JA} in °C/W for the PSOP package with various areas and weights of copper are tabulated below.

TABLE 2. Thermal Resistance of PSOP Package

Copper	Area	0.5 in ² (each side)	1.0 in ² (each side)	2.0 in ² (each side)
0.5 oz	Top	115	105	102
1.0 oz	Layer	91	79	72
2.0 oz	Only	74	60	52
0.5 oz	Bottom	102	88	81
1.0 oz	Layer	92	75	65
2.0 oz	Only	85	66	54
0.5 oz	Top And	83	70	63
1.0 oz	Bottom	71	57	47
2.0 oz		63	48	37

Table 2 clearly demonstrates the superior thermal qualities of the exposed pad package. For example, using the topside copper only in the same way as shown for the SOIC package (Figure 2), the PSOP requires half the area of 1 oz copper (2 in², total or 1300mm²), for a comparable thermal resistance of 72°C/Watt. This gives considerably more flexibility in the pcb layout aside from using less copper.

The shape of the heat sink shown in Figure 2 is necessary to allow external components to be connected to the package pins. If thermal vias are used beneath the PSOP to the bottom side ground plane, then a square pattern heat sink can be used and there is no restriction on component placement on the top side of the board. Even better thermal characteristics are obtained with bottom layer heat sinking. A 2 inch square of 0.5oz copper gives the same thermal resistance (81°C/W) as a competitive thermally enhanced 8-Pin SOIC package which needs two layers of 2 oz copper, each 4 in² (for a total of 5000 mm²). With heavier copper, thermal resistances as low as 54°C/W are possible with bottom side heat sinking only, substantially improving the long term reliability since the maximum junction temperature is held to less than 110°C, even with an ambient temperature of 85°C. If both top and bottom copper planes are used, the thermal resistance can be brought to under 40°C/W.

HIGH FREQUENCY/LARGE SIGNAL SWING CONSIDERATIONS

The LM7372 employs a unique input stage in order to support large slew rate and high output current capability with large output swings, with a relatively low quiescent current. This input architecture boosts the device supply current when the application demands it. The result is a supply current which increases at high enough frequencies when the output swing is large enough with added power dissipation as a consequence.

Figure 3 shows the amount of increase in supply current as a function of frequency for various sinusoidal output swing amplitudes:

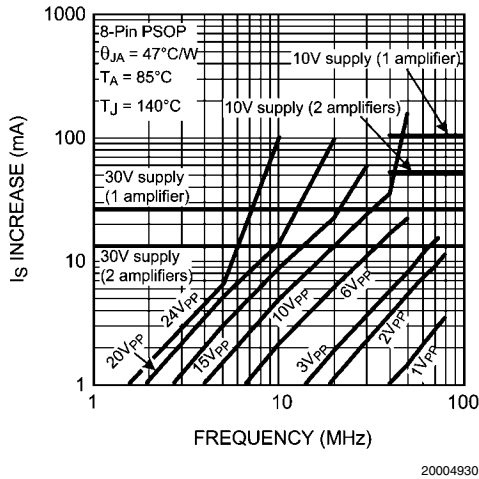

FIGURE 3. Power Supply Current Increase

Figure 3 shows that there could be 1mA or more excess supply current per amplifier with close to full output swing (24V_{PP}) when frequency is just above 1MHz (or at higher frequencies when the output swing is less). This boost in supply current enables the output to “keep up” with high frequency/large signal output swing, but in turn, increases the total package power dissipation and therefore raises the device junction temperature. As a consequence, these demanding applications, especially ones which run at higher supply voltages, need special attention to the package heatsink design. For that reason, Figure 3 has the safe operating limits for the 8-Pin PSOP package (e.g. “30V supply (2 amplifiers)” horizontal line) superimposed on top of it (with T_J limit of 140°C when operated at 85°C ambient), so that the designer can readily decide whether or not there is need for additional heat sinking.

For example, if the LM7372 is operating similarly to Figure 1 schematic with a single power supply of 10V, Figure 3 shows that it is safe to have up to 10V_{PP} output swing at up to 40MHz with no additional heat sinking. This determination is from inspection of Figure 3 where the “10V supply (2 amplifiers)” safe operating limit intercepts the 10V_{PP} swing graph at around 40MHz. Use the “10V supply (1 amplifier)” safe operating limit line in cases where the second amplifier in the LM7372 package does not experience high frequency/high output swing conditions.

At any given “I_S increase” value (y axis), the product of frequency and output swing remains essentially constant for all output swing plots. This holds true for the lower frequency range before the plots experience a slope increase. Therefore, if the application example just discussed operates up to 60MHz instead, it is possible to calculate the junction-temperature-limited maximum output swing of 6.7V_{PP} (= 40MHz x 10V_{PP}/60MHz) instead.

Please note that Figure 3 precludes any additional amplifier power dissipation related to load (this topic is discussed below in detail). This load current, if large enough, will reduce the operating frequency/output swing further. It is important to note that the LM7372 can be destroyed if it is allowed to dissipate enough power that compromises its maximum junction temperature limit of 150°C.

With the op amp tied to a load, the device power dissipation consists of the quiescent power due to the supply current flow into the device, in addition to power dissipation due to the load current. The load portion of the power itself could include an

average value (due to a DC load current) and an AC component. DC load current would flow if there is an output voltage offset, or the output AC average current is non-zero, or if the op amp operates in a single supply application where the output is maintained somewhere in the range of linear operation. Therefore:

$$P_{D(TOTAL)} = P_Q + P_{DC} + P_{AC}$$

$$P_Q = I_S \cdot V_S \quad \text{Op Amp Quiescent Power Dissipation}$$

$$P_{DC} = I_O \cdot (V_R - V_O) \quad \text{DC Load Power}$$

$$P_{AC} = \text{See Table 3 below} \quad \text{AC Load Power}$$

where:

I_S Supply Current

V_S Total Supply Voltage (V⁺ - V⁻)

I_O Average Load Current

V_O Average Output Voltage

V_R Reference Voltage (V⁺ for sourcing and V⁻ for sinking current)

Table 3 below shows the maximum AC component of the load power dissipated by the op amp for standard Sinusoidal, Triangular, and Square Waveforms:

TABLE 3. Normalized maximum AC Power Dissipated in the Output Stage for Standard Waveforms

P _{AC} (W.Ω/V ²)		
Sinusoidal	Triangular	Square
50.7 x 10 ⁻³	46.9 x 10 ⁻³	62.5 x 10 ⁻³

The table entries are normalized to V_S²/R_L. These entries are computed at the output swing point where the amplifier dissipation is the highest for each waveform type. To figure out the AC load current component of power dissipation, simply multiply the table entry corresponding to the output waveform by the factor V_S²/R_L. For example, with ±5V supplies, a 100Ω load and triangular output waveform, power dissipation in the output stage is calculated as: P_{AC} = 46.9 x 10⁻³ x 102/100 = 46.9mW which contributes another 2.2°C (= 46.9mW x 47°C/W) rise to the LM7372 junction temperature in the 8-Pin PSOP package.

POWER SUPPLIES

The LM7372 is fabricated on a high voltage, high speed process. Using high supply voltages ensures adequate headroom to give low distortion with large signal swings. In Figure 1, a single 24V supply is used. To maximize the output dynamic range the non-inverting inputs are biased to half supply voltage by the resistive divider R1, R2. The input signals are AC coupled and the coupling capacitors (C1, C2) can be scaled with the bias resistors (R3, R4) to form a high pass filter if unwanted coupling from the POTS signal occurs.

Supply decoupling is important at both low and high frequencies. The 10μF Tantalum and 0.1μF Ceramic capacitors should be connected close to the supply Pin 14. Note that the V⁻ pin (pin 6), and the PCB area associated with the heatsink (Pins 1,8,9 & 16) are at the same potential. Any layout should avoid running input signal leads close to this ground plane, or unwanted coupling of high frequency supply currents may generate distortion products.

Although this application shows a single supply, conversion to a split supply is straightforward. The half supply resistive divider network is eliminated and the bias resistors at the non-

inverting inputs are returned to ground, see *Figure 4* (the pin numbers in *Figure 4* are given for PSOP package, those in *Figure 1* are for the SOIC package). With a split supply, note that the ground plane and the heatsink copper must be separate and are at different potentials, with the heatsink (pin 4 of the PSOP, pins 6,1,8,9 &16 of the SOIC) now at a negative potential (V^-).

In either configuration, the area under the input pins should be kept clear of copper (Whether ground plane copper or heatsink copper) to avoid parasitic coupling to the inputs.

The LM7372 is stable with non inverting closed loop gains as low as +2. Typical of any voltage feedback operational amplifier, as the closed loop gain of the LM7372 is increased, there is a corresponding reduction in the closed loop signal bandwidth. For low distortion performance it is recommended to keep the closed loop bandwidth at least 10X the highest signal frequency. This is because there is less loop gain (the difference between the open loop gain and the closed loop gain) available at higher frequencies to reduce harmonic distortion terms.

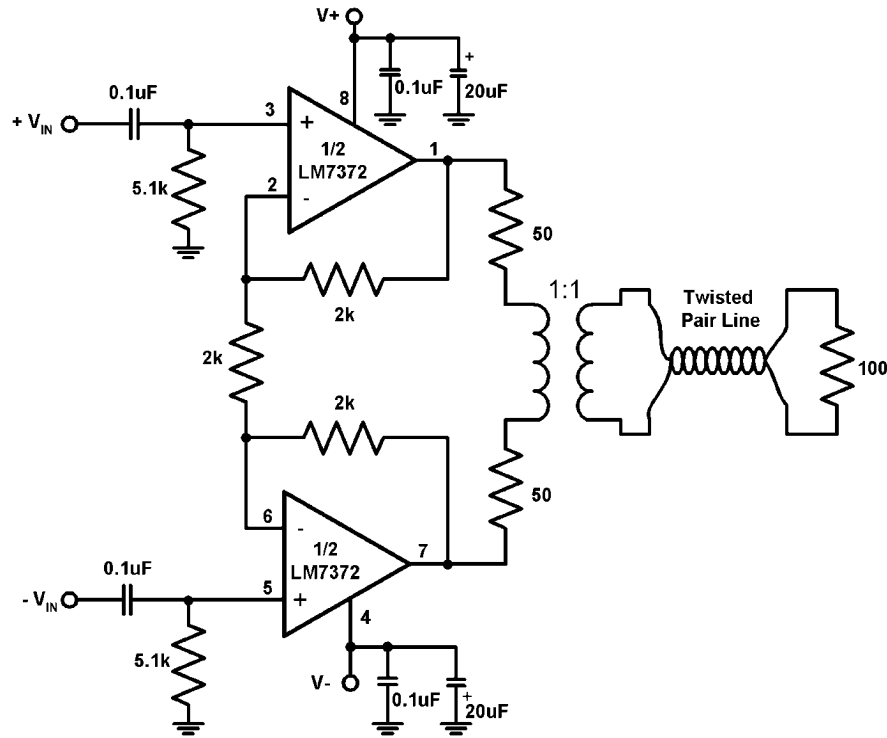

20004926

FIGURE 4. Split Supply Application (PSOP)

PRINTED CIRCUIT BOARD LAYOUT and EVALUATION BOARDS

Generally, a good high-frequency layout will keep power supply and ground traces away from the inverting input and output pins. Parasitic capacitance on these nodes to ground will cause frequency response peaking and possible circuit oscillations (see Application Note OA-15 for more information). National Semiconductor suggests the following evaluation boards as a guide for high frequency layout and as an aid in device testing and characterization:

Device	Package	Evaluation Board PN
LM7372MA	16-Pin SOIC	None
LM7372MR	8-Pin PSOP	CLC730121

These free evaluation boards are shipped automatically when a device sample request is placed with National Semiconductor.

The DAP (die attach paddle) on the 8-Pin PSOP should be tied to V^- . It should not be tied to ground. See the respective Evaluation Board documentation.

Physical Dimensions inches (millimeters) unless otherwise noted

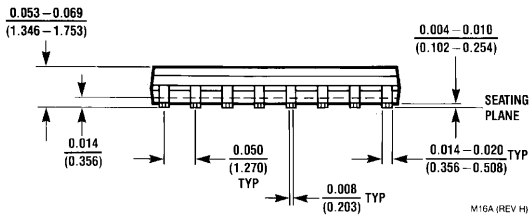
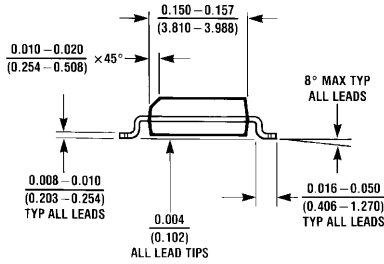
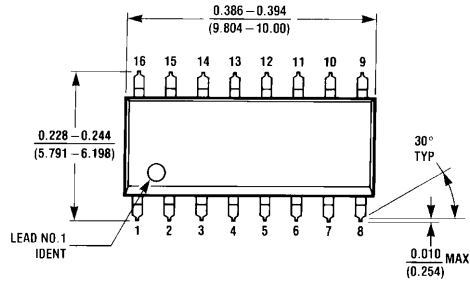

16-Pin SOIC
NS Package Number M16A

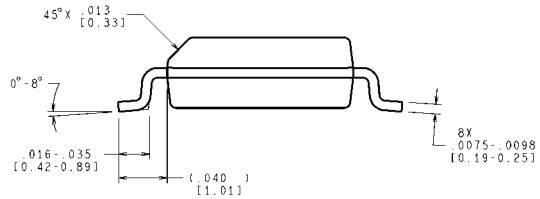
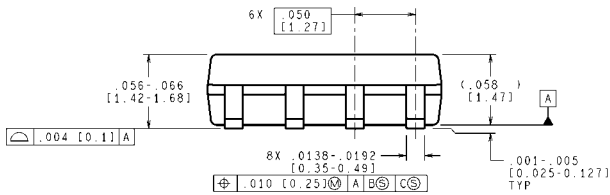
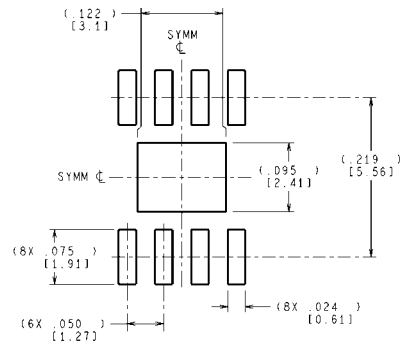
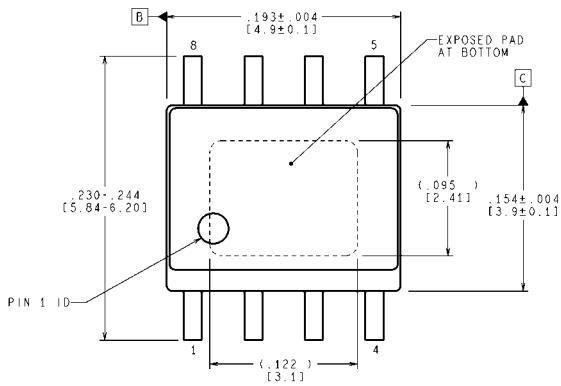

CONTROLLING DIMENSION IS INCH
VALUES IN [] ARE MILLIMETERS
DIMENSIONS IN () FOR REFERENCE ONLY

8-Pin PSOP
NS Package Number MRA08B

MRA08B (Rev B)

Notes

For more National Semiconductor product information and proven design tools, visit the following Web sites at:

Products		Design Support	
Amplifiers	www.national.com/amplifiers	WEBENCH	www.national.com/webench
Audio	www.national.com/audio	Analog University	www.national.com/AU
Clock Conditioners	www.national.com/timing	App Notes	www.national.com/appnotes
Data Converters	www.national.com/adc	Distributors	www.national.com/contacts
Displays	www.national.com/displays	Green Compliance	www.national.com/quality/green
Ethernet	www.national.com/ethernet	Packaging	www.national.com/packaging
Interface	www.national.com/interface	Quality and Reliability	www.national.com/quality
LVDS	www.national.com/lvds	Reference Designs	www.national.com/refdesigns
Power Management	www.national.com/power	Feedback	www.national.com/feedback
Switching Regulators	www.national.com/switchers		
LDOs	www.national.com/ldo		
LED Lighting	www.national.com/led		
PowerWise	www.national.com/powerwise		
Serial Digital Interface (SDI)	www.national.com/sdi		
Temperature Sensors	www.national.com/tempsensors		
Wireless (PLL/VCO)	www.national.com/wireless		

THE CONTENTS OF THIS DOCUMENT ARE PROVIDED IN CONNECTION WITH NATIONAL SEMICONDUCTOR CORPORATION ("NATIONAL") PRODUCTS. NATIONAL MAKES NO REPRESENTATIONS OR WARRANTIES WITH RESPECT TO THE ACCURACY OR COMPLETENESS OF THE CONTENTS OF THIS PUBLICATION AND RESERVES THE RIGHT TO MAKE CHANGES TO SPECIFICATIONS AND PRODUCT DESCRIPTIONS AT ANY TIME WITHOUT NOTICE. NO LICENSE, WHETHER EXPRESS, IMPLIED, ARISING BY ESTOPPEL OR OTHERWISE, TO ANY INTELLECTUAL PROPERTY RIGHTS IS GRANTED BY THIS DOCUMENT.

TESTING AND OTHER QUALITY CONTROLS ARE USED TO THE EXTENT NATIONAL DEEMS NECESSARY TO SUPPORT NATIONAL'S PRODUCT WARRANTY. EXCEPT WHERE MANDATED BY GOVERNMENT REQUIREMENTS, TESTING OF ALL PARAMETERS OF EACH PRODUCT IS NOT NECESSARILY PERFORMED. NATIONAL ASSUMES NO LIABILITY FOR APPLICATIONS ASSISTANCE OR BUYER PRODUCT DESIGN. BUYERS ARE RESPONSIBLE FOR THEIR PRODUCTS AND APPLICATIONS USING NATIONAL COMPONENTS. PRIOR TO USING OR DISTRIBUTING ANY PRODUCTS THAT INCLUDE NATIONAL COMPONENTS, BUYERS SHOULD PROVIDE ADEQUATE DESIGN, TESTING AND OPERATING SAFEGUARDS.

EXCEPT AS PROVIDED IN NATIONAL'S TERMS AND CONDITIONS OF SALE FOR SUCH PRODUCTS, NATIONAL ASSUMES NO LIABILITY WHATSOEVER, AND NATIONAL DISCLAIMS ANY EXPRESS OR IMPLIED WARRANTY RELATING TO THE SALE AND/OR USE OF NATIONAL PRODUCTS INCLUDING LIABILITY OR WARRANTIES RELATING TO FITNESS FOR A PARTICULAR PURPOSE, MERCHANTABILITY, OR INFRINGEMENT OF ANY PATENT, COPYRIGHT OR OTHER INTELLECTUAL PROPERTY RIGHT.

LIFE SUPPORT POLICY

NATIONAL'S PRODUCTS ARE NOT AUTHORIZED FOR USE AS CRITICAL COMPONENTS IN LIFE SUPPORT DEVICES OR SYSTEMS WITHOUT THE EXPRESS PRIOR WRITTEN APPROVAL OF THE CHIEF EXECUTIVE OFFICER AND GENERAL COUNSEL OF NATIONAL SEMICONDUCTOR CORPORATION. As used herein:

Life support devices or systems are devices which (a) are intended for surgical implant into the body, or (b) support or sustain life and whose failure to perform when properly used in accordance with instructions for use provided in the labeling can be reasonably expected to result in a significant injury to the user. A critical component is any component in a life support device or system whose failure to perform can be reasonably expected to cause the failure of the life support device or system or to affect its safety or effectiveness.

National Semiconductor and the National Semiconductor logo are registered trademarks of National Semiconductor Corporation. All other brand or product names may be trademarks or registered trademarks of their respective holders.

Copyright© 2008 National Semiconductor Corporation

For the most current product information visit us at www.national.com



National Semiconductor Americas Technical Support Center
Email: support@nsc.com
Tel: 1-800-272-9959

National Semiconductor Europe Technical Support Center
Email: europe.support@nsc.com
German Tel: +49 (0) 180 5010 771
English Tel: +44 (0) 870 850 4288

National Semiconductor Asia Pacific Technical Support Center
Email: ap.support@nsc.com

National Semiconductor Japan Technical Support Center
Email: jpn.feedback@nsc.com

IMPORTANT NOTICE

Texas Instruments Incorporated and its subsidiaries (TI) reserve the right to make corrections, modifications, enhancements, improvements, and other changes to its products and services at any time and to discontinue any product or service without notice. Customers should obtain the latest relevant information before placing orders and should verify that such information is current and complete. All products are sold subject to TI's terms and conditions of sale supplied at the time of order acknowledgment.

TI warrants performance of its hardware products to the specifications applicable at the time of sale in accordance with TI's standard warranty. Testing and other quality control techniques are used to the extent TI deems necessary to support this warranty. Except where mandated by government requirements, testing of all parameters of each product is not necessarily performed.

TI assumes no liability for applications assistance or customer product design. Customers are responsible for their products and applications using TI components. To minimize the risks associated with customer products and applications, customers should provide adequate design and operating safeguards.

TI does not warrant or represent that any license, either express or implied, is granted under any TI patent right, copyright, mask work right, or other TI intellectual property right relating to any combination, machine, or process in which TI products or services are used. Information published by TI regarding third-party products or services does not constitute a license from TI to use such products or services or a warranty or endorsement thereof. Use of such information may require a license from a third party under the patents or other intellectual property of the third party, or a license from TI under the patents or other intellectual property of TI.

Reproduction of TI information in TI data books or data sheets is permissible only if reproduction is without alteration and is accompanied by all associated warranties, conditions, limitations, and notices. Reproduction of this information with alteration is an unfair and deceptive business practice. TI is not responsible or liable for such altered documentation. Information of third parties may be subject to additional restrictions.

Resale of TI products or services with statements different from or beyond the parameters stated by TI for that product or service voids all express and any implied warranties for the associated TI product or service and is an unfair and deceptive business practice. TI is not responsible or liable for any such statements.

TI products are not authorized for use in safety-critical applications (such as life support) where a failure of the TI product would reasonably be expected to cause severe personal injury or death, unless officers of the parties have executed an agreement specifically governing such use. Buyers represent that they have all necessary expertise in the safety and regulatory ramifications of their applications, and acknowledge and agree that they are solely responsible for all legal, regulatory and safety-related requirements concerning their products and any use of TI products in such safety-critical applications, notwithstanding any applications-related information or support that may be provided by TI. Further, Buyers must fully indemnify TI and its representatives against any damages arising out of the use of TI products in such safety-critical applications.

TI products are neither designed nor intended for use in military/aerospace applications or environments unless the TI products are specifically designated by TI as military-grade or "enhanced plastic." Only products designated by TI as military-grade meet military specifications. Buyers acknowledge and agree that any such use of TI products which TI has not designated as military-grade is solely at the Buyer's risk, and that they are solely responsible for compliance with all legal and regulatory requirements in connection with such use.

TI products are neither designed nor intended for use in automotive applications or environments unless the specific TI products are designated by TI as compliant with ISO/TS 16949 requirements. Buyers acknowledge and agree that, if they use any non-designated products in automotive applications, TI will not be responsible for any failure to meet such requirements.

Following are URLs where you can obtain information on other Texas Instruments products and application solutions:

Products

Audio	www.ti.com/audio
Amplifiers	amplifier.ti.com
Data Converters	dataconverter.ti.com
DLP® Products	www.dlp.com
DSP	dsp.ti.com
Clocks and Timers	www.ti.com/clocks
Interface	interface.ti.com
Logic	logic.ti.com
Power Mgmt	power.ti.com
Microcontrollers	microcontroller.ti.com
RFID	www.ti-rfid.com
OMAP Mobile Processors	www.ti.com/omap
Wireless Connectivity	www.ti.com/wirelessconnectivity

Applications

Communications and Telecom	www.ti.com/communications
Computers and Peripherals	www.ti.com/computers
Consumer Electronics	www.ti.com/consumer-apps
Energy and Lighting	www.ti.com/energy
Industrial	www.ti.com/industrial
Medical	www.ti.com/medical
Security	www.ti.com/security
Space, Avionics and Defense	www.ti.com/space-avionics-defense
Transportation and Automotive	www.ti.com/automotive
Video and Imaging	www.ti.com/video

TI E2E Community Home Page

e2e.ti.com

Mailing Address: Texas Instruments, Post Office Box 655303, Dallas, Texas 75265
Copyright © 2011, Texas Instruments Incorporated