

Description

The Smart Power Relay E-1048-8I.- is a remotely controllable electronic load disconnecting relay with three functions in a single unit:

- electronic relay
- electronic overcurrent protection
- status indication

The 7 pin INLINE version is designed for use with various E-T-A terminal blocks, e. g. 17-P10-Si. A choice of current ratings is available from 1 A through 20 A. An operating voltage range of DC 9...32 V allows the connection of DC 12 V and DC 24 V loads.

In order to switch and protect loads remotely, it has until now been necessary to connect several discreet components together:

- an electro-mechanic relay, control cable and integral contact to close the load circuit
- an additional protective element (circuit breaker or fuse) for cable or equipment protection
- a device for current measurement (shunt)

Now type E-1048-8I. combines all these functions in a single unit, thus minimising the number of connections in the circuit and thereby reducing the risk of failures.

Applications

Type E-1048-8I. is suited to all applications with DC 12 V or DC 24 V circuits, where magnetic valves, motors or lamp loads have to be switched, protected or monitored:

- road vehicles (utility vehicles, buses, special vehicles)
- rail vehicles
- marine industry (ships, boats, yachts etc.)

The Power Relay is also suitable for industrial use (process control, machine-building, engineering) as an electronic coupling relay between PLC and DC 12 V or DC 24 V load

Features

- Integral power electronics provide a wear-resistant switching function, insensitive to shock and vibration.
- Only a fraction of the control power needed by electro-mechanical relays is required for switching loads. This is important for battery buffered load circuits which have to remain controlled even with the generator off line.
- The extremely low induced current consumption of less than 1 mA is absolutely necessary for battery buffered applications.
- The load circuit is disconnected in the event of an overload or short circuit, the trip curve is also suitable for smaller motor loads.
- The load circuit is permanently monitored for wire breakage.
- Two status outputs for control signal AS and group signal SF provide status indication. For processing the actual value of the current flow in a power management system an analogue output from 0 to 5 V is provided. This voltage signal may also be used as an input to a control circuit or to switch off the unit by means of external control in the event of low load current value.
- For switching and monitoring loads of 20 A plus it is possible to connect several units in parallel. Uniform power distribution between units must be ensured by symmetrical design of the supply cables (length and cross section).
- Coloured label, e. g. red = 10 A, see ordering information.



E-1048-8I. INLINE

Technical Data ($T_U = 25^\circ\text{C}$, $U_S = \text{DC } 24\text{ V}$) ($T_U =$ ambient temperature at U_N)

Power supply LINE +

Type	DC power supply with small R_i battery and generator etc.
Voltage ratings U_N	DC 12 V / DC 24 V
Operating voltage U_S :	DC 9...32 V

Load circuit LOAD

Load output	Power MOSFET, high side switching
Max. current rating I_N	20 A
Types of loads	resistive, inductive, capacitive, lamp loads, motors (depending on duration of inrush current)
Current rating range I_N	1 A...15 A (fixed ratings) up to 85°C ambient without load reduction, 20 A up to 70°C . Two basic versions with factory pre-set ratings: version 1: 1 A/2 A/3 A/5 A/7.5 A/10 A version 2: 15 A / 20 A

Induced current consumption I_0 of the unit (OFF condition) < 1 mA

Typical voltage drop U_{ON} at rated current I_N (at 25°C)

I_N	U_{ON}	I_N	U_{ON}
1 A	50 mV	7.5 A	90 mV
2 A	55 mV	10 A	110 mV
3 A	60 mV	15 A	60 mV
5 A	80 mV	20 A	60 mV

Switching point typically $1.3 \times I_N$ ($-40^\circ\text{C} \dots +85^\circ\text{C}$: $1.1 \dots 1.5 \times I_N$)

Trip time (standard curve) typically 200 ms with switch-on onto overload and/or load increase on duty

Current limitation
version 1: typically 75 A
version 2: typically 350 A

Temperature disconnection power transistor > 150°C
After trip
- resettable via external control signal (low-high) at control input IN+
- reset of supply voltage

Parallel connection of channels for loads of 20 A plus, several units of identical current ratings may be connected in parallel. To ensure equal distribution of current between units, symmetrical design of the supply feed is necessary (length and cross section).

Leakage current in OFF condition
version 1: max. 100 μA
version 2: max. 500 μA

Free-wheeling diode for connected load
integral
version 1: max. 40 A
version 2: max. 100 A

Technical Data ($T_U = 25\text{ °C}$, $U_S = \text{DC } 24\text{ V}$) ($T_U = \text{ambient temperature at } U_N$)

Delay time t_{on} / t_{off} (resistive load)	typically 5 ms / typically 1.5 ms (EMC filter in control input)
Wire breakage monitoring in ON and OFF condition of load	<p>wire breakage thresholds:</p> <p>in OFF-condition (version 1): $R_{load} > \text{typically } 100\text{ k}\Omega$</p> <p>in OFF-condition (version 2): $R_{load} > \text{typically } 10\text{ k}\Omega$</p> <p>in ON-condition: $I_{load} < \text{typically } 0.2 \times I_N$</p> <p>indication via group fault signalisation FM (switching output)</p> <p>Fault indication will not be stored, i.e. after remedy of wire breakage fault indication will disappear (possible options:</p> <ul style="list-style-type: none"> - wire breakage indication only in ON condition - wire breakage indication only in OFF condition - no wire breakage indication) <p>- disconnection of load, indication via group signal SF</p> <ul style="list-style-type: none"> - no automatic re-start - after remedy of the fault unit has to be reset via control input IN+
Short circuit, overload in load circuit	<ul style="list-style-type: none"> - disconnection of load, indication via group signal SF - no automatic re-start - after remedy of the fault unit has to be reset via control input IN+

Control input IN+

Control voltage IN+	0...5 V = "OFF", 8.5...32 V = "ON"
Control current I_E	1...10 mA (8.5...DC 32 V)
Reset in the event of a failure (e.g. PWM signal)	<ul style="list-style-type: none"> - reset via external control signal (low - high) at control input IN+ - via reset of supply voltage possible, see max. switching frequency

Switching frequency at resistive or inductive load max. 100 Hz

Status and diagnostic function

Control signal AS	transistor output minus switching (LSS), open collector, short circuit and overload proof, max. load: DC 32 V/2 A 0 V-level: when unit is set (at IN+ = 8.4...32 V)
Group signal SF	transistor output minus switching (LSS), open collector, short circuit and overload proof, load max. DC 32 V/2 A 0 V-level with overload and short circuit disconnection, wire breakage indication voltage output 0-5 V proportional to load current: 1 V = $0.2 \times I_N$ 5 V = $1.0 \times I_N$ 5 V... typically 6.5 V = overload range tolerance: (for $I_{load} > 0.2 \times I_N$) $\pm 8\%$ of I_N max. output current 5 mA load resistance $> 1\text{ k}\Omega$ against GND
Analogue output U(I)	response time when switching on a load: $t_{90} = \text{typically } 20\text{ ms}$ response time of load change on duty: $t_{90} = \text{typically } 1\text{ ms}$
Trip times definition of t_{90} reached 90% of final value	

Visual status indication

Control signal AS	LED yellow
Group fault signal SF	LED red

Technical Data ($T_U = 25\text{ °C}$, $U_S = \text{DC } 24\text{ V}$) ($T_U = \text{ambient temperature at } U_N$)

General data

Reverse polarity protection

Control circuit	yes
Load circuit	no (due to integral free-wheeling diode)
Status outputs	interference voltage resistance max. DC 32 V

Temperature range

ambient temperature	- standard: -40...+85 °C without load reduction (70 °C at 20 A) - for other temperature ranges please see ordering key
---------------------	--

Tests

Humid heat	combined test, 9 cycles with functional test test to DIN EN 60068-2-30, Z/AD
Temperature change	min. temperature -40 °C, max. temperature +90 °C test to DIN IEC 60068-2-14, Nb
Vibration (random)	in operation, with temperature change 6 g eff. (10 Hz...2,000 Hz) test to DIN EN 60068-2-64
Shock	25 g/11 ms, 10 shocks test to DIN EN 60068-2-27
Corrosion Protection class	test to DIN EN 60068-2-52, severity 3 housing IP30 to DIN 40050 higher protection class upon request
EMC requirements	EMC directive: emitted interference EN 50081-1 noise immunity EN 61000-6-2 Automotive directive: emitted interference, noise immunity: 72/245/EW6 und 95/54/E6

Terminals of INLINE version (7 pin, standard)

Mounting:	7 blade terminals 6.3 mm x 0.8 mm to DIN 46244-A6.3-0.8 contact material CuZn37F37 copper-plated and tin-plated - E-T-A socket type 17-P10-Si (max. load 16 A) - on a pc board with 6.3 mm receptacles
-----------	---

Housing

max. dimensions	INLINE: 11.5 x 50 x 56 mm when plugged in 11.5 x 50 x 66 mm including terminals
Materials	INLINE: Ultramid
Mass	approx. 23 g...33 g, depending on version

Approvals CE, e1 logo

according to EU, EMC and automotive directives

Ordering Information

Type

E-1048-8I Smart Power Relay DC 12 V/24 V - 1 A...20 A in INLINE housing

Housing / temperature range

- 3** with housing / 70 °C (without moisture condensation)
- 4** with housing / -40 °C...+85 °C (70 °C at I_N = 20 A)

C with control input (+ control 8.5...32 V)

LEDs

- 0** without LEDs
- 3** 2 LEDs: AS yellow, SF red

Status output minus-switching

- A** without
- D** with AS and SF

Contents of group fault signal SF/ LED indication SF

- 0** without
- 1** short circuit / overload
- 2** short circuit / overload + wire breakage off
- 3** short circuit / overload + wire breakage on
- 4** short circuit / overload + wire breakage off + wire breakage on

Analogue output

- V0** without
- V1** 0...5 V

Characteristic curve

- 4** 200 ms (switch-off delay with overload)

Voltage rating

U3 DC 12/24 V

Current ratings / colour of label

- 1 A** / black
- 2 A** / grey
- 3 A** / purple
- 5 A** / light-brown
- 7.5 A** / brown
- 10 A** / red
- 15 A** / blue
- 20 A** / yellow

E-1048-8I 4 - C 3 D 4 V1-4 U3 - 20 A

ordering example 1: (all options = "DELUXE")

E-1048-8I 3 - C 0 A 0 V0-4 U3 - 5 A

ordering example 2: (without options = "BASIC")

Dimensions

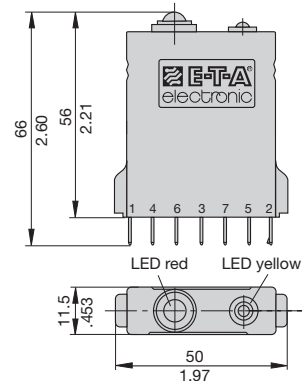

This is a metric design and millimeter dimensions take precedence ($\frac{\text{mm}}{\text{inch}}$)

Connection diagram

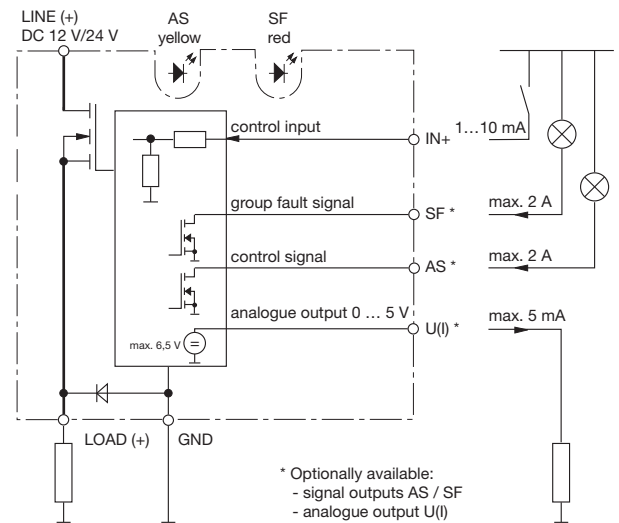

Pin selection

E-1048-8I.	17-P10-Si	
LINE + (2)	(2) [2(k)]	
GND (5)	(5) [12]	
SF (7)	(7) [24]	
U(I) (3)	(3) [2(i)]	
AS (6)	(6) [23]	
IN+ (4)	(4) [11]	
LOAD (1)	(1) [1]	

Typical time/current characteristics ($T_A = 25\text{ °C}$)

Version 1: 1 A, 2 A, 3 A, 5 A, 7.5 A and 10 A (standard 200 ms)

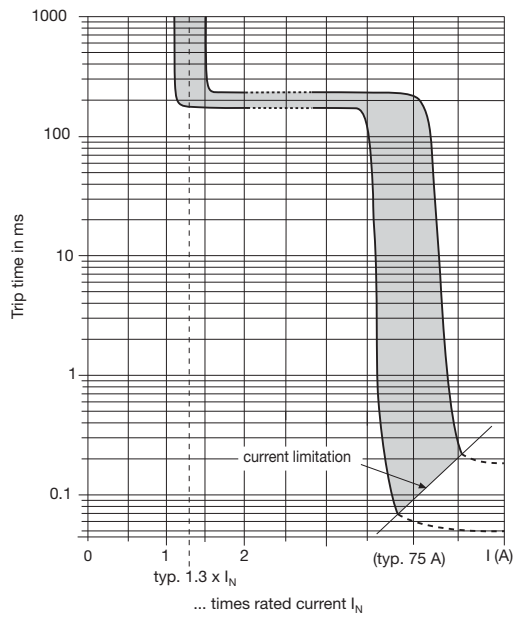

Version 2: 15 A and 20 A (standard 200 ms)

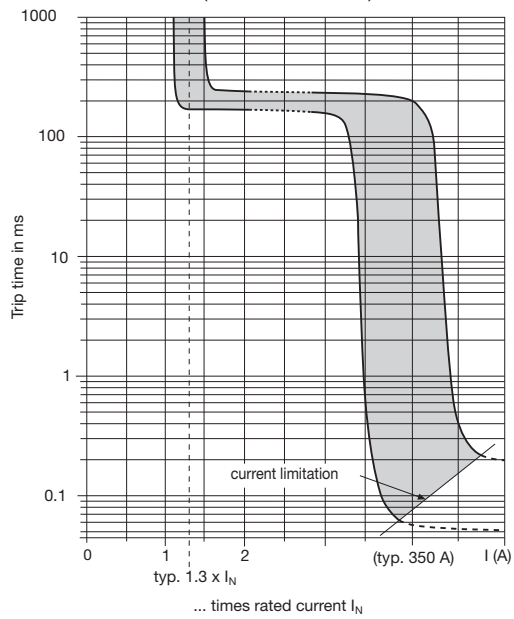

Accessories for E-1048-8I.

Single mounting sockets

(up to 16 A max. load)

17-P10-Si

17-P70-Si

(retaining clip Y 300 581 11 available on request)

(with adapter)

17-P10-Si-20025

17-P70-Si-20025

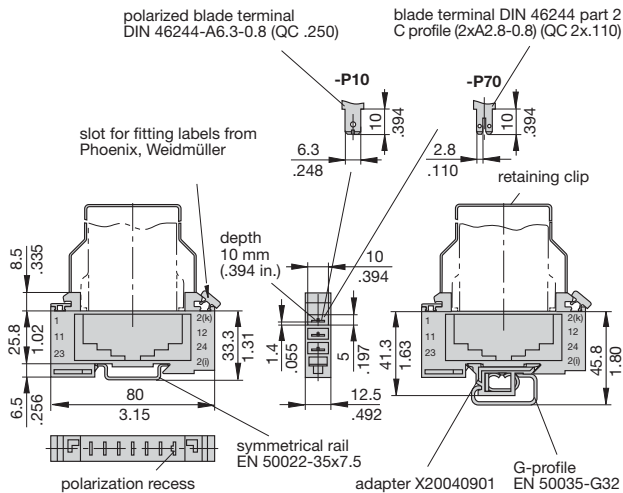

Busbar (10-way) (supplied as a complete package) for type 17 socket

(for max. 100 A continuous load, more positions available on request)

X 211 157 01 with terminal

X 211 157 02 without terminal

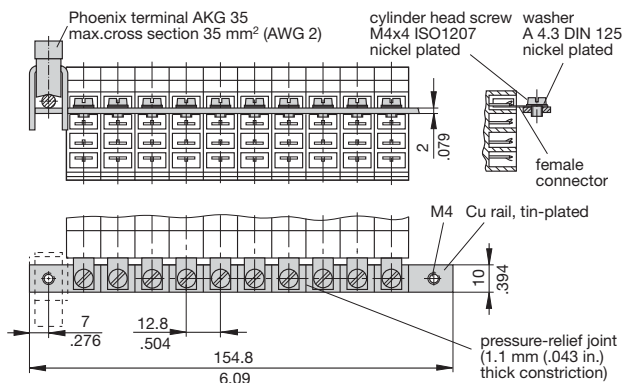

Insulating sleeving for busbar (10-way) Y 303 824 01

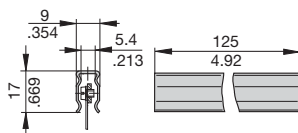

2-way mounting socket

23-P10-Si

(retaining clip Y 300 581 03 available on request)

6-way mounting socket

63-P10-Si

(retaining clip Y 300 581 03 available on request)

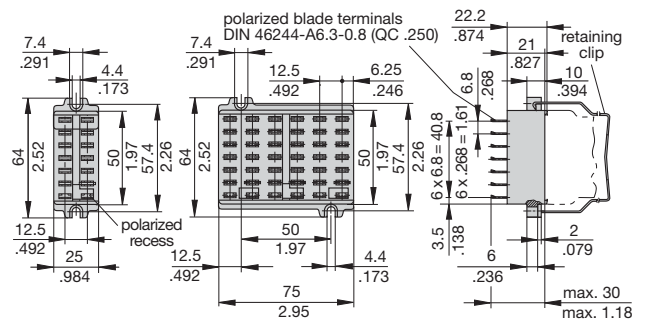

Connector bus links -P10

X 210 588 01 / 1.5 mm², (AWG 16), brown (up to 13 A max. load)

X 210 588 02 / 2.5 mm², (AWG 14), black (up to 20 A max. load)

X 210 588 03 / 2.5 mm², (AWG 14), red (up to 20 A max. load)

X 210 588 04 / 2.5 mm², (AWG 14), blue (up to 20 A max. load)

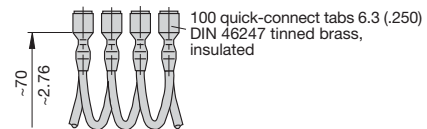

2 mounting clips Y 300 504 02

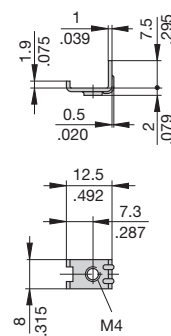

Installation drawing with mounting clips Y 300 504 02

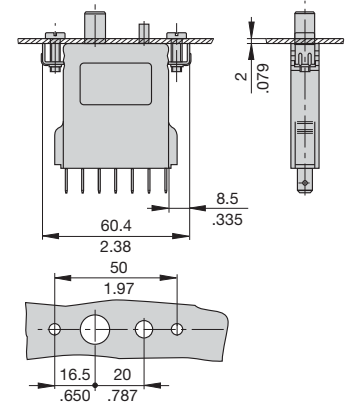

This is a metric design and millimeter dimensions take precedence ($\frac{\text{mm}}{\text{inch}}$)

All dimensions without tolerances are for reference only. In the interest of improved design, performance and cost effectiveness the right to make changes in these specifications without notice is reserved. Product markings may not be exactly as the ordering codes. Errors and omissions excepted.