

Cushioned Prox. Mount

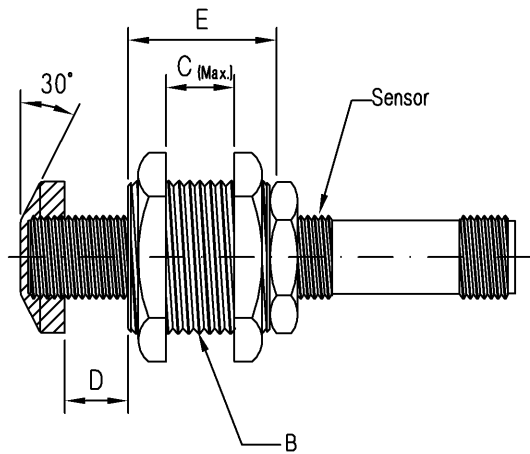

Dimensions in (mm)

Part number	Sensor type	B	Maximum mounting torque	C	D	E	Min. force to actuate	Force required for full stroke
BESA-08-CM	M8 x 1	M16 x 1.5	6.0 Nm*	11	10	19	1.36 N	6.76 N
BESA-12-CM	M12 x 1	M22 x 1.5	15.0 Nm**	10	12.1	19	5.56 N	10.49 N
BESA-18-CM	M18 x 1	M30 x 1.5	40.0 Nm	15.2	10	25	4.04 N	7.79 N
BESA-30-CM	M30 x 1.5	M47 x 1.5	40.0 Nm	25	15	35	6.60 N	24.46 N

Specifications

Material: Anodized Aluminum
 Cap material: Delrin
 Mounting nuts: Brass
 Storage temperature: -51° to +121° C
 Operating temperature: -45° to +85° C
 Maximum number of operating cycles: 2,000,000

Mounting Instructions

1. Drill clearance hole for the size sensor being used.
2. Thread sensor nut (supplied with sensor) on barrel approximately 1 3/4" (44.5mm) from sensor face.
3. Slip outside sleeve over barrel to sensor nut.
4. Thread inner sleeve on barrel to recommended position (see Dimension "D").
5. Lock sensor nut down to inner sleeve using Loctite thread locker (see sensor nut torque).
6. Slip assembly into clearance hole (see Dimension "B") and tighten mounting nuts (see mounting nut torque specification chart).
7. Thread end cap to sensor barrel - use Loctite.
8. End cap should not touch threaded sleeve.

Notes:

Nm rating is for the potted area of the sensor, for other areas the rating is 15.0 Nm

* - Can also be used with M5 sensors, in which case the Maximum Mounting Torque is 1.5 Nm; 6.0

** - 15.0 Nm rating is for the potted area of the sensor; for other areas the rating is 40.0 Nm

Specifications subject to change without notice.
 2 RCA 26.NOV.2007 Mod.-No.02 108183
 3 BALLUFF Inc. 8125 Holton Drive Florence, KY 41042
 Phone: 1-800-543-8390 Fax: 1-859-727-4823