

10 9 8 7 6 5 4 3 2 1

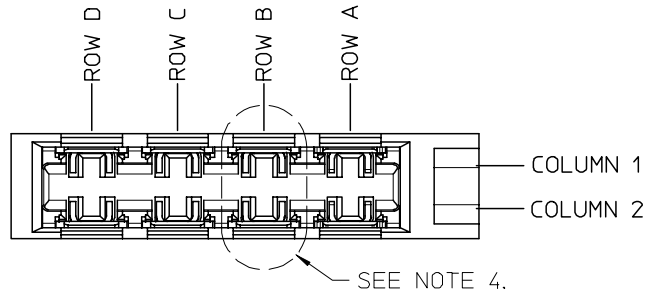

- NOTES:
1. MATERIALS: HOUSING - LIQUID CRYSTAL POLYMER (LCP), UL 94V-0, GRAY; CONTACT - COPPER ALLOY.
 2. FINISH: SELECT GOLD IN CONTACT AREA, 50 μ" THICK; TIN/LEAD OR MATTE TIN IN COMPLIANT AREA.
 3. PACKAGING PER PK-70873-562.
 4. CONTACTS IN EACH ROW HAVE THE SAME WIPE LENGTH.
 5. BACKPLANE ASSEMBLY MATES WITH DAUGHTERCARD POWER MODULE 75292-4***.
 6. PART SHOWN IS 75343-4467 (SHEET 4).
 7. SEE OTHER SHEETS FOR ADDITIONAL NOTES.
 8. WHEN INSERTING OPEN SIGNAL MODULES NEXT TO COLUMN 1 SIDE OF POWER MODULES, SIGNAL MODULES MUST BE INSERTED BEFORE THE POWERS TO AVOID INTERFERENCE BETWEEN THE TWO CONNECTOR HOUSINGS.
 9. THESE PARTS CONFORM TO MOLEX PRODUCT SPECIFICATION PS-75221-999.
 10. THESE PARTS CONFORM TO MOLEX COSMETIC SPECIFICATION PS-45499-002 CLASS B.

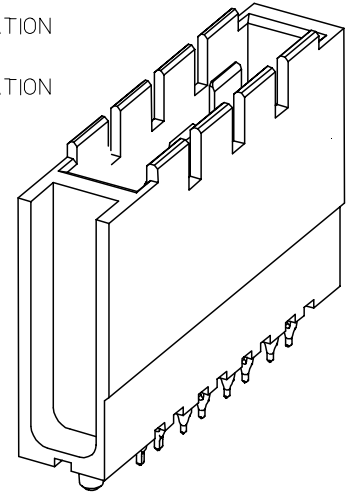
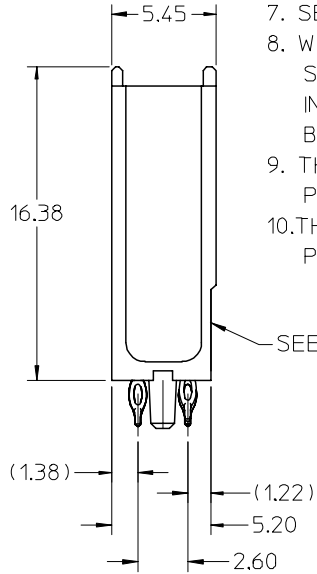
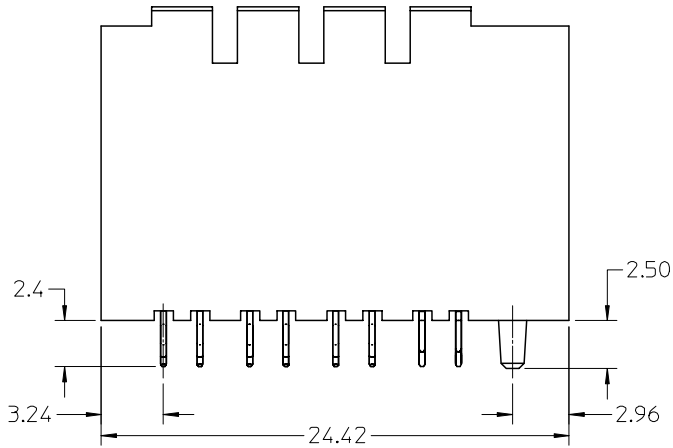

1-UP ASSEMBLY PART NUMBER

7 5 3 4 1 - A B C D
 - TIN/LEAD PLATED PRODUCT -
 FOR EACH ROW LOCATION A, B, C, D:
 0 = VOID
 4 = 4.5 mm WIPE
 6 = 6.0 mm WIPE
 7 = 7.5 mm WIPE
 - LEAD-FREE PLATED PRODUCT -
 FOR EACH ROW LOCATION A, B, C, D:
 0 = VOID
 2 = 4.5 mm WIPE
 3 = 6.0 mm WIPE
 5 = 7.5 mm WIPE

ADDED NOTES 9 & 10 EC NO: UCP2008-0426 DRAWN: C STEWART 2007/08/29 CHKD: 2007/08/30 APPR: J B INGHAM 2007/08/31	DESCRIPTION REV C	QUALITY SYMBOLS	GENERAL TOLERANCES (UNLESS SPECIFIED)	DIMENSION STYLE	SCALE	DESIGN UNITS	THIRD ANGLE PROJECTION																		
		$\nabla=0$ $\nabla=0$	<table border="1"> <thead> <tr> <th></th> <th>mm</th> <th>INCH</th> </tr> </thead> <tbody> <tr> <td>4 PLACES</td> <td>±----</td> <td>±----</td> </tr> <tr> <td>3 PLACES</td> <td>±----</td> <td>±----</td> </tr> <tr> <td>2 PLACES</td> <td>±----</td> <td>±----</td> </tr> <tr> <td>1 PLACE</td> <td>±----</td> <td>±----</td> </tr> <tr> <td colspan="3">ANGULAR ±---°</td> </tr> </tbody> </table>		mm	INCH	4 PLACES	±----	±----	3 PLACES	±----	±----	2 PLACES	±----	±----	1 PLACE	±----	±----	ANGULAR ±---°			MM ONLY	4:1	METRIC	
			mm	INCH																					
		4 PLACES	±----	±----																					
3 PLACES	±----	±----																							
2 PLACES	±----	±----																							
1 PLACE	±----	±----																							
ANGULAR ±---°																									
		<table border="1"> <tr> <td>DRAWN BY</td> <td>DATE</td> </tr> <tr> <td>ELO</td> <td>2006/04/06</td> </tr> <tr> <td>CHECKED BY</td> <td>DATE</td> </tr> <tr> <td>ELO</td> <td>2005/02/22</td> </tr> <tr> <td>APPROVED BY</td> <td>DATE</td> </tr> <tr> <td>CUNNINGHAM</td> <td>2005/02/23</td> </tr> </table>	DRAWN BY	DATE	ELO	2006/04/06	CHECKED BY	DATE	ELO	2005/02/22	APPROVED BY	DATE	CUNNINGHAM	2005/02/23	TITLE										
DRAWN BY	DATE																								
ELO	2006/04/06																								
CHECKED BY	DATE																								
ELO	2005/02/22																								
APPROVED BY	DATE																								
CUNNINGHAM	2005/02/23																								
		DRAFT WHERE APPLICABLE MUST REMAIN WITHIN DIMENSIONS	SEE CHART	MATERIAL NO.	DOCUMENT NO.	MOLEX INCORPORATED GBX 4 PAIR BACKPLANE POWER SALES ASSEMBLY SD-75341-001																			
			SIZE B	THIS DRAWING CONTAINS INFORMATION THAT IS PROPRIETARY TO MOLEX INCORPORATED AND SHOULD NOT BE USED WITHOUT WRITTEN PERMISSION			SHEET NO. 1 OF 4																		

9 8 7 6 5 4 3 2 1

10 9 8 7 6 5 4 3 2 1

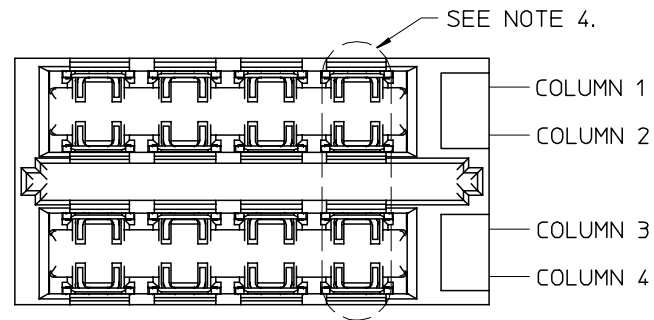

2-UP ASSEMBLY PART NUMBER

7 5 3 4 2 - A B C D
 - TIN/LEAD PLATED PRODUCT -
 FOR EACH ROW LOCATION A, B, C, D:
 0 = VOID
 4 = 4.5 mm WIPE
 6 = 6.0 mm WIPE
 7 = 7.5 mm WIPE
 - LEAD-FREE PLATED PRODUCT -
 FOR EACH ROW LOCATION A, B, C, D:
 0 = VOID
 2 = 4.5 mm WIPE
 3 = 6.0 mm WIPE
 5 = 7.5 mm WIPE

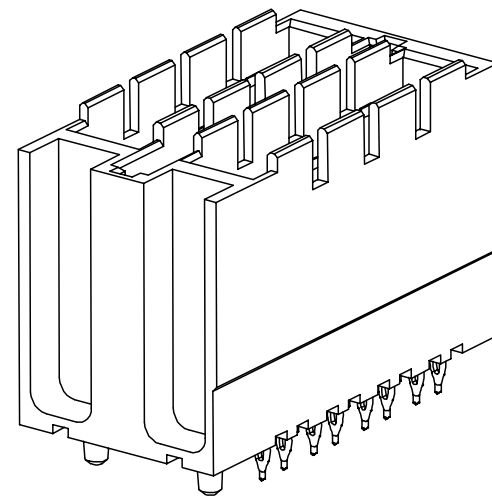
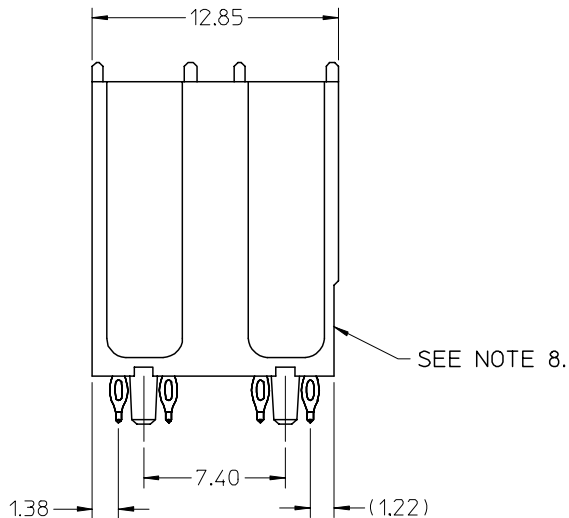
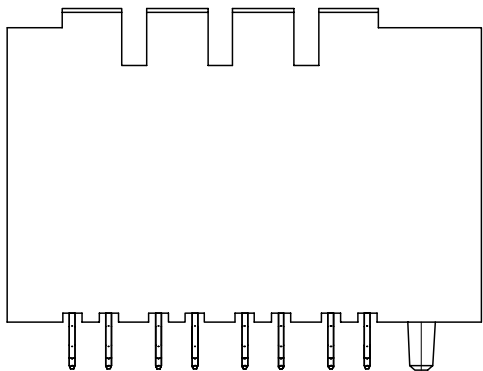

SEE SHEET 1 FOR ADDITIONAL INFORMATION
 CHECK WITH PRODUCT MANAGER FOR AVAILABILITY

SEE SHEET ONE EC NO: UCP2008-0426 DRWN: C STEWART 2007/08/29 CHKD: 2007/08/30 APPR: J B INGHAM 2007/08/31	QUALITY SYMBOLS ▽=0 ▽=0	GENERAL TOLERANCES (UNLESS SPECIFIED)		DIMENSION STYLE MM ONLY	SCALE 4:1	DESIGN UNITS METRIC	THIRD ANGLE PROJECTION		
		4 PLACES	± ---	± ---	DRAWN BY ELO	DATE 2006/04/06	TITLE GBX 4 PAIR BACKPLANE POWER SALES ASSEMBLY		
		3 PLACES	± ---	± ---	CHECKED BY	DATE 2005/02/22	APPROVED BY CUNNINGHAM		
2 PLACES	± ---	± ---	1 PLACE	± ---	DATE 2005/02/23	MATERIAL NO. SEE CHART			
			ANGULAR	± ---°	DATE	DOCUMENT NO. SD-75341-001			
			DRAFT WHERE APPLICABLE MUST REMAIN WITHIN DIMENSIONS		SIZE B	SHEET NO. 2 OF 4			
			THIS DRAWING CONTAINS INFORMATION THAT IS PROPRIETARY TO MOLEX INCORPORATED AND SHOULD NOT BE USED WITHOUT WRITTEN PERMISSION						

9 8 7 6 5 4 3 2 1

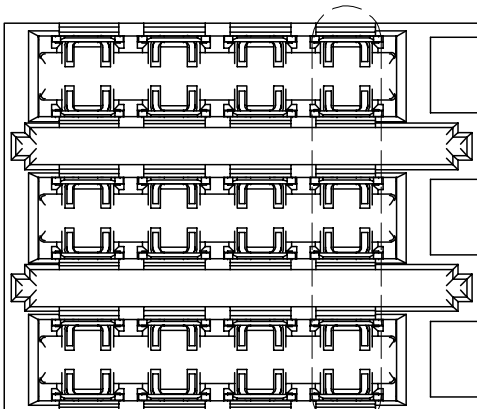

COLUMN 1
 COLUMN 2
 COLUMN 3
 COLUMN 4
 COLUMN 5
 COLUMN 6

3-UP ASSEMBLY PART NUMBER
 7 5 3 4 3 - A B C D
 - TIN/LEAD PLATED PRODUCT -
 FOR EACH ROW LOCATION A, B, C, D:
 0 = VOID
 4 = 4.5 mm WIPE
 6 = 6.0 mm WIPE
 7 = 7.5 mm WIPE
 - LEAD-FREE PLATED PRODUCT -
 FOR EACH ROW LOCATION A, B, C, D:
 0 = VOID
 2 = 4.5 mm WIPE
 3 = 6.0 mm WIPE
 5 = 7.5 mm WIPE

SEE NOTE 4.

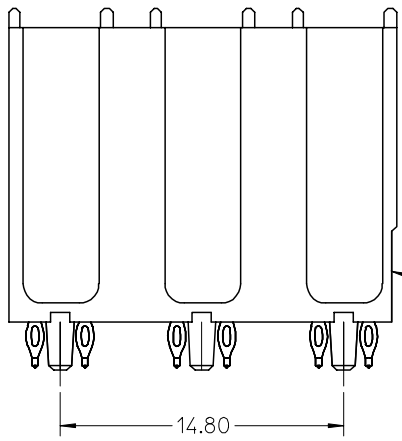
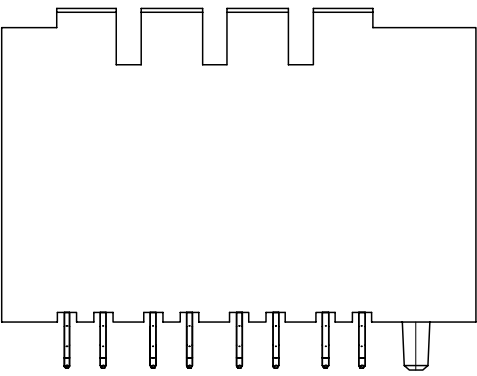

SEE NOTE 8.

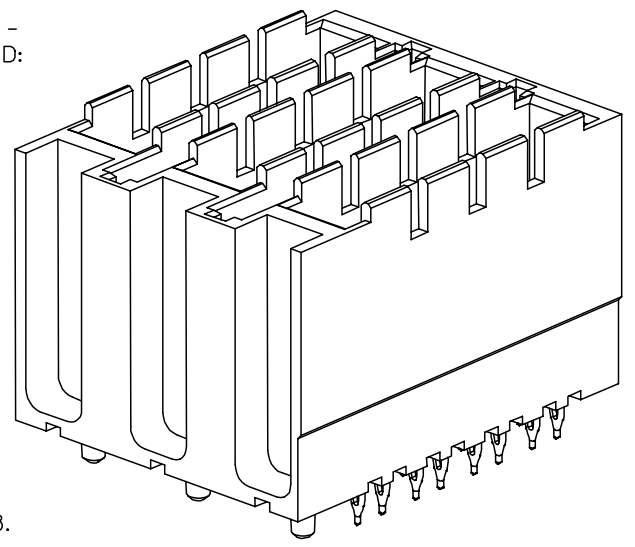

SEE SHEET 1 FOR ADDITIONAL INFORMATION
 CHECK WITH PRODUCT MANAGER FOR AVAILABILITY

SEE SHEET ONE EC NO: UCP2008-0426 DRW: JSTEWART 2007/08/29 CHKD: 2007/08/30 APPR: J. INGHAM 2007/08/31	QUALITY SYMBOLS ▽=0 ▽=0	GENERAL TOLERANCES (UNLESS SPECIFIED)		DIMENSION STYLE MM ONLY		SCALE 4:1	DESIGN UNITS METRIC	THIRD ANGLE PROJECTION	
			mm	INCH	DRAWN BY ELO	DATE 2006/04/06	TITLE GBX 4 PAIR BACKPLANE POWER SALES ASSEMBLY		
		4 PLACES ± ---	± ---	± ---	CHECKED BY ELO	DATE 2005/02/22	APPROVED BY CUNNINGHAM		
		3 PLACES ± ---	± ---	± ---	DATE 2005/02/23	DOCUMENT NO. SD-75341-001			
			2 PLACES ± ---	± ---	± ---	MATERIAL NO.		SHEET NO.	
			1 PLACE ± ---	± ---	± ---	SEE CHART		3 OF 4	
			ANGULAR ± ---°		DRAFT WHERE APPLICABLE MUST REMAIN WITHIN DIMENSIONS		THIS DRAWING CONTAINS INFORMATION THAT IS PROPRIETARY TO MOLEX INCORPORATED AND SHOULD NOT BE USED WITHOUT WRITTEN PERMISSION		

10 9 8 7 6 5 4 3 2 1

SEE NOTE 5.

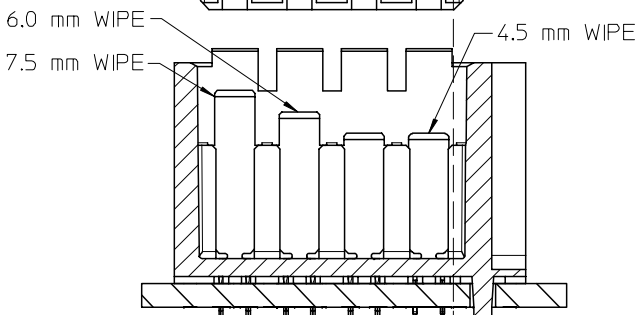
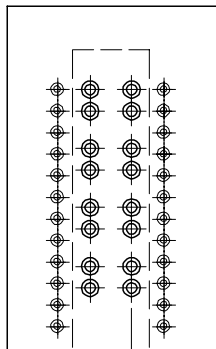
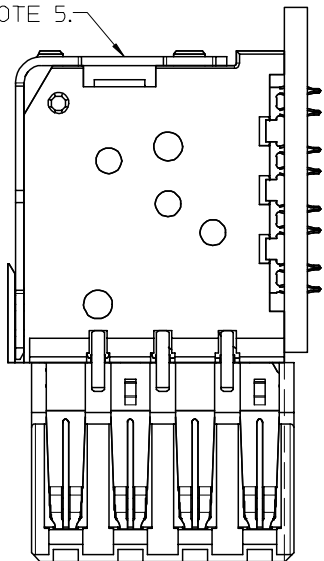

0.76
DC BOARD EDGE TO
CENTERLINE OF BP TAIL

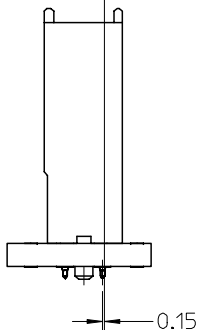

HOLE PATTERN FOR 1-UP ASSEMBLY

- 1.) ADD 7.40 FROM CENTERLINES OF PEGS FOR MULTIPLE UP ASSEMBLIES.
- 2.) ADD 5.55 FROM CENTERLINE TO CENTERLINE OF PEG FOR INDIVIDUAL POWER MODULES STACKED NEXT TO EACH OTHER.

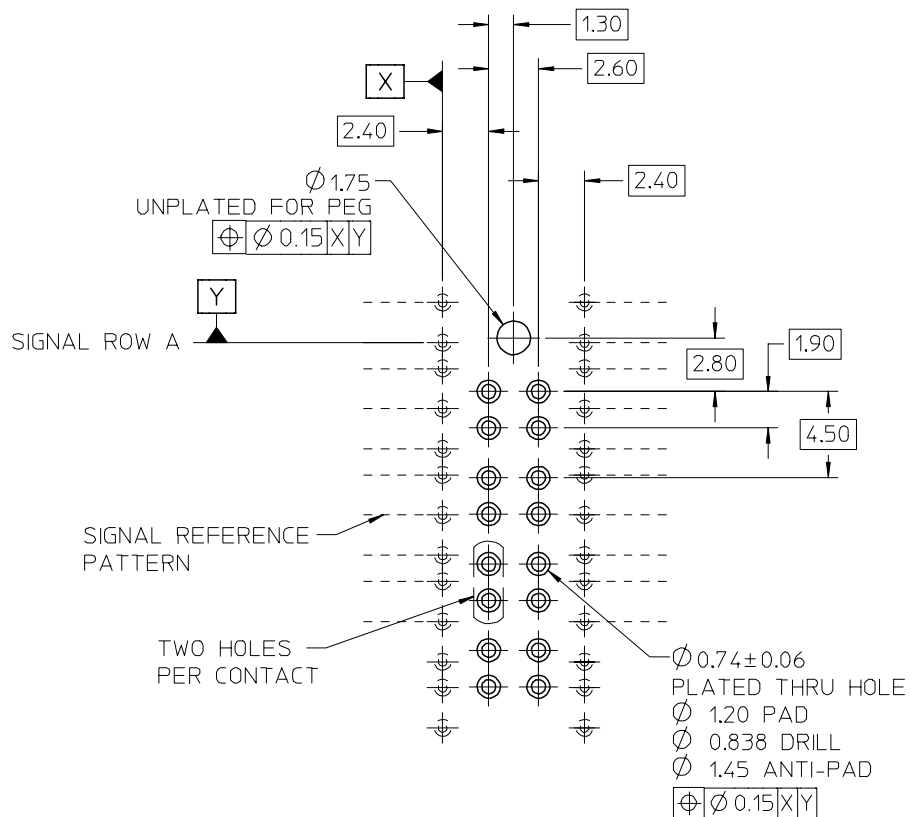

ADDED $\phi 0.74 \pm 0.06$ EC NO: UCF2008-0426 DRWN: C STEWART 2007/08/29 CHKD: J BINGHAM 2007/08/30 APPR: J BINGHAM 2007/08/31	QUALITY SYMBOLS $\nabla = 0$ $\nabla = 0$	GENERAL TOLERANCES (UNLESS SPECIFIED)		DIMENSION STYLE MM ONLY		SCALE 4:1	DESIGN UNITS METRIC	THIRD ANGLE PROJECTION																	
		<table border="1"> <thead> <tr> <th></th> <th>mm</th> <th>INCH</th> </tr> </thead> <tbody> <tr> <td>4 PLACES</td> <td>± ---</td> <td>± ---</td> </tr> <tr> <td>3 PLACES</td> <td>± ---</td> <td>± ---</td> </tr> <tr> <td>2 PLACES</td> <td>± ---</td> <td>± ---</td> </tr> <tr> <td>1 PLACE</td> <td>± ---</td> <td>± ---</td> </tr> </tbody> </table>			mm	INCH	4 PLACES	± ---	± ---	3 PLACES	± ---	± ---	2 PLACES	± ---	± ---	1 PLACE	± ---	± ---	DRAWN BY ELO 2006/04/06		DATE		TITLE		GBX 4 PAIR BACKPLANE POWER SALES ASSEMBLY MOLEX INCORPORATED
			mm	INCH																					
		4 PLACES	± ---	± ---																					
3 PLACES	± ---	± ---																							
2 PLACES	± ---	± ---																							
1 PLACE	± ---	± ---																							
CHECKED BY ELO 2005/02/22		DATE		APPROVED BY CUNNINGHAM 2005/02/23		DATE		MOLEX SD-75341-001																	
ANGULAR ± --- °		MATERIAL NO.		DOCUMENT NO.		SHEET NO.																			
DRAFT WHERE APPLICABLE MUST REMAIN WITHIN DIMENSIONS		SEE PREVIOUS		THIS DRAWING CONTAINS INFORMATION THAT IS PROPRIETARY TO MOLEX INCORPORATED AND SHOULD NOT BE USED WITHOUT WRITTEN PERMISSION		4 OF 4																			

9 8 7 6 5 4 3 2 1