



**Have a Question?**  
 Chat with a Product Information Specialist

What can we help you find?

[Products](#) [Industries](#) [Resources](#) [About TE](#) [My Account](#) [Innovation](#) [Support Center](#)

**1-66101-9 Product Details**

[Share](#) [Print](#) [Email](#)

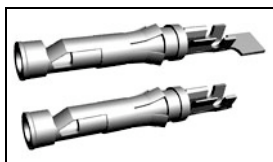

**1-66101-9**

TE Internal Number: 1-66101-9

Active

[View 3D PDF](#)

**Multimate**

Always EU RoHS/ELV Compliant (Statement of Compliance)

**Product Highlights:**

- Contact Type = Socket
- Contact Classification = Signal
- Type III+ Series
- Bright Tin Contact Plating, Mating Area, Material
- Wire Range = 0.80-1.40<sup>2</sup> [18-16] mm [AWG]

[View all Features](#)

**Quick Links**

- ▶ [Pricing & Availability](#)
- ▶ [Search for Tooling](#)
- ▶ [Product Feature Selector](#)
- ▶ [Contact Us About This Product](#)

[Add to My Part List](#) [Request Sample](#) [Find Similar Products](#) [Buy Product](#)

Documentation & Additional Information	
<p><b>Product Drawings:</b></p> <ul style="list-style-type: none"> <li>• <a href="#">SOCKET ASSEMBLY, LOOSE PIECE, TYPE III+ (PDF, English)</a></li> </ul> <p><b>Catalog Pages/Data Sheets:</b></p> <ul style="list-style-type: none"> <li>• <a href="#">Signal Contacts (PDF, English)</a></li> <li>• <a href="#">M_SERIES_PIN_AND_SOCKET_CONNECTORS (PDF, English)</a></li> <li>• <a href="#">AMP Circular Connectors for Commercial Signal &amp; Powe... (PDF, English)</a></li> </ul> <p><b>Product Specifications:</b></p> <ul style="list-style-type: none"> <li>• <a href="#">Type III+ Stamped and Formed Contacts (PDF, English)</a></li> </ul> <p><b>Application Specifications:</b></p> <ul style="list-style-type: none"> <li>• <a href="#">Type III+ (Size 16) Contacts (PDF, English)</a></li> </ul> <p><b>Instruction Sheets:</b></p> <ul style="list-style-type: none"> <li>• None Available</li> </ul> <p><b>CAD Files:</b> (<a href="#">CAD Format &amp; Compression Information</a>)</p> <ul style="list-style-type: none"> <li>• <a href="#">2D Drawing (DXF, Version Z)</a></li> <li>• <a href="#">3D Model (IGES, Version Z)</a></li> <li>• <a href="#">3D Model (STEP, Version Z)</a></li> </ul>	<p><b>Additional Information:</b></p> <ul style="list-style-type: none"> <li>• <a href="#">Product Line Information</a></li> </ul> <p><b>Related Products:</b></p> <ul style="list-style-type: none"> <li>• <a href="#">Tooling</a></li> </ul>

[List all Documents](#)

Product Features (Please use the Product Drawing for all design activity)	
<p><b>Product Type Features:</b></p> <ul style="list-style-type: none"> <li>• Series = Type III+</li> <li>• Insulation Support = Yes</li> <li>• Termination Method to Wire/Cable = Crimp</li> <li>• Wire/Cable Type = Discrete Wire</li> <li>• Grade = Commercial</li> </ul> <p><b>Electrical Characteristics:</b></p> <ul style="list-style-type: none"> <li>• High Current = No</li> </ul> <p><b>Termination Features:</b></p> <ul style="list-style-type: none"> <li>• <a href="#">Termination End Plating</a> = Bright Tin</li> </ul> <p><b>Dimensions:</b></p> <ul style="list-style-type: none"> <li>• Pin Diameter (mm [in]) = 1.57 [0.062]</li> </ul> <p><b>Body Features:</b></p> <ul style="list-style-type: none"> <li>• <a href="#">Wire Range (mm [AWG])</a> = 0.80-1.40<sup>2</sup> [18-16]</li> <li>• Spring Material = Stainless Steel</li> <li>• Used With = G Series Connectors, M Series Connectors, CPC Connectors</li> </ul> <p><b>Contact Features:</b></p> <ul style="list-style-type: none"> <li>• Contact Type = Socket</li> <li>• Contact Classification = Signal</li> <li>• <a href="#">Contact Plating, Mating Area, Material</a> = Bright Tin</li> <li>• <a href="#">Contact Base Material</a> = Brass</li> <li>• <a href="#">Contact Size</a> = 16</li> </ul>	<p><b>Industry Standards:</b></p> <ul style="list-style-type: none"> <li>• <a href="#">RoHS/ELV Compliance</a> = RoHS compliant, ELV compliant</li> <li>• <a href="#">Lead Free Solder Processes</a> = Not relevant for lead free process</li> <li>• RoHS/ELV Compliance History = Always was RoHS compliant</li> </ul> <p><b>Conditions for Usage:</b></p> <ul style="list-style-type: none"> <li>• <a href="#">Accepts Wire Insulation Diameter, Range (mm [in])</a> = 2.03 - 2.54 [0.080 - 0.100]</li> <li>• <a href="#">Applies To</a> = Wire/Cable</li> <li>• Test Current (A) = 13.0</li> </ul> <p><b>Packaging Features:</b></p> <ul style="list-style-type: none"> <li>• <a href="#">Packaging Method</a> = Loose Piece</li> <li>• Packaging Quantity = 1,000 Box/Carton</li> </ul> <p><b>Other:</b></p> <ul style="list-style-type: none"> <li>• Brand = AMP</li> <li>• Comment = PRO-CRIMPER II # 58495-1 Hand Tool for field repair use only.; Overall insulation crimp diameter, including crimp barrel, must not exceed 3.18 [.125].; Insertion Tool No. 91002-1 (for Insulation Dia. 1.78 [.070] or less), No. 200893-2 (for Insulation Dia. .090 [2.29] max.) Extraction Tool No. 305183.</li> </ul>

THIS DRAWING IS UNPUBLISHED. RELEASED FOR PUBLICATION  
 © COPYRIGHT - By - ALL RIGHTS RESERVED.

LOC	DIST	REVISIONS			
P	LTR	DESCRIPTION	DATE	DWN	APVD
FT	47	E	REVISED PER ECO-12-012320	04JUL12	KH MZ

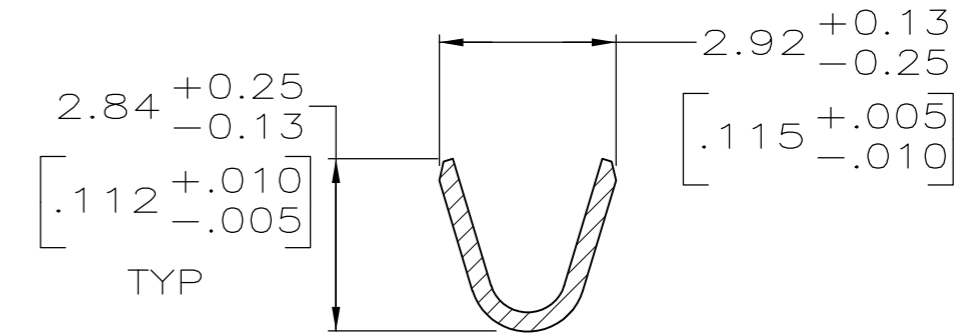
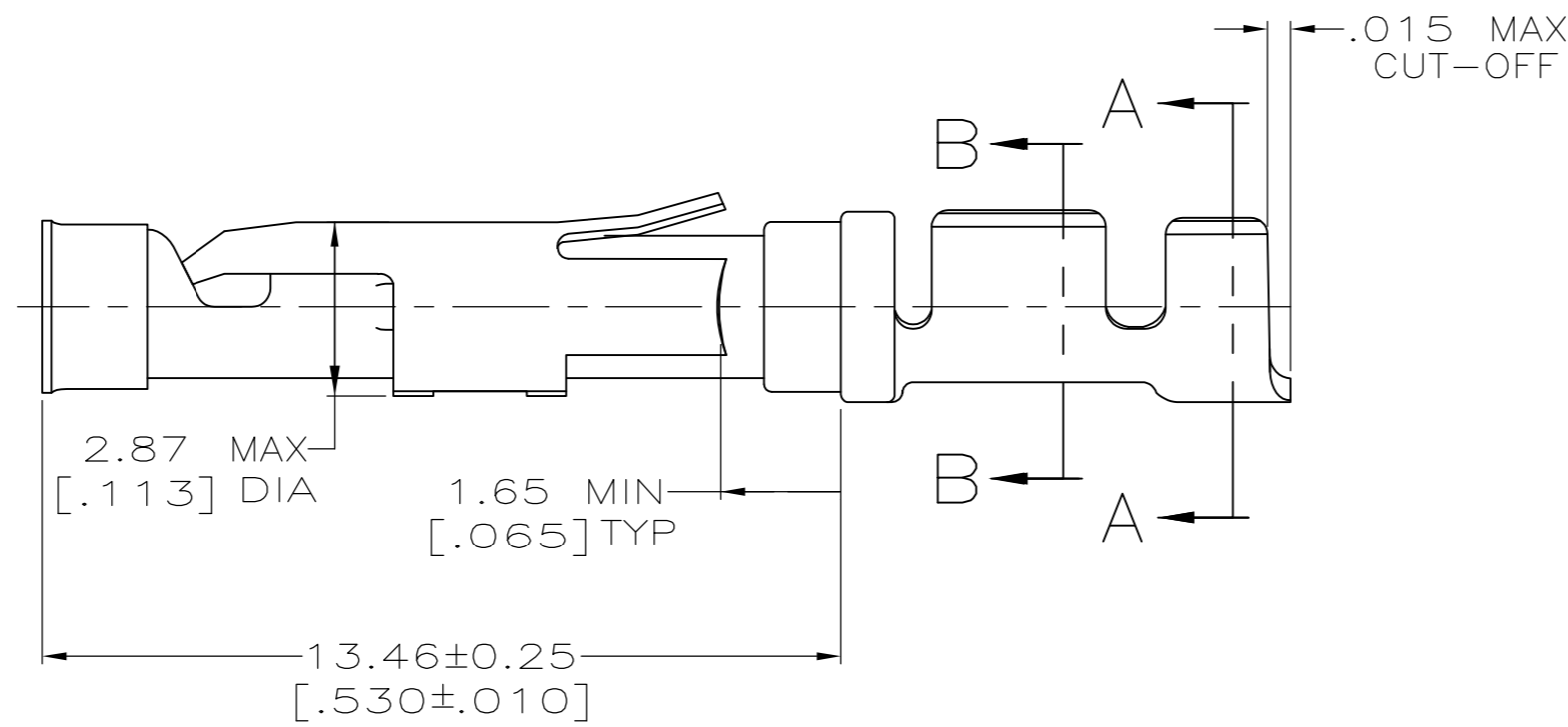
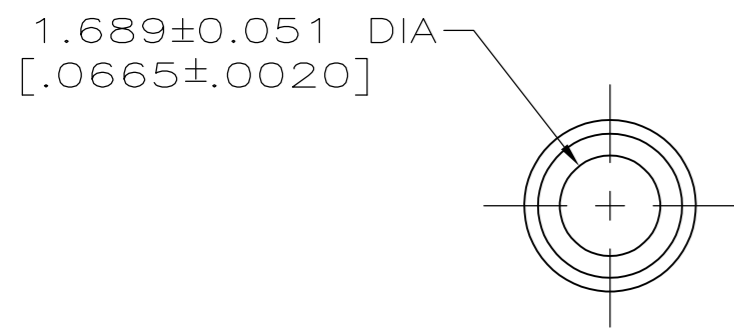
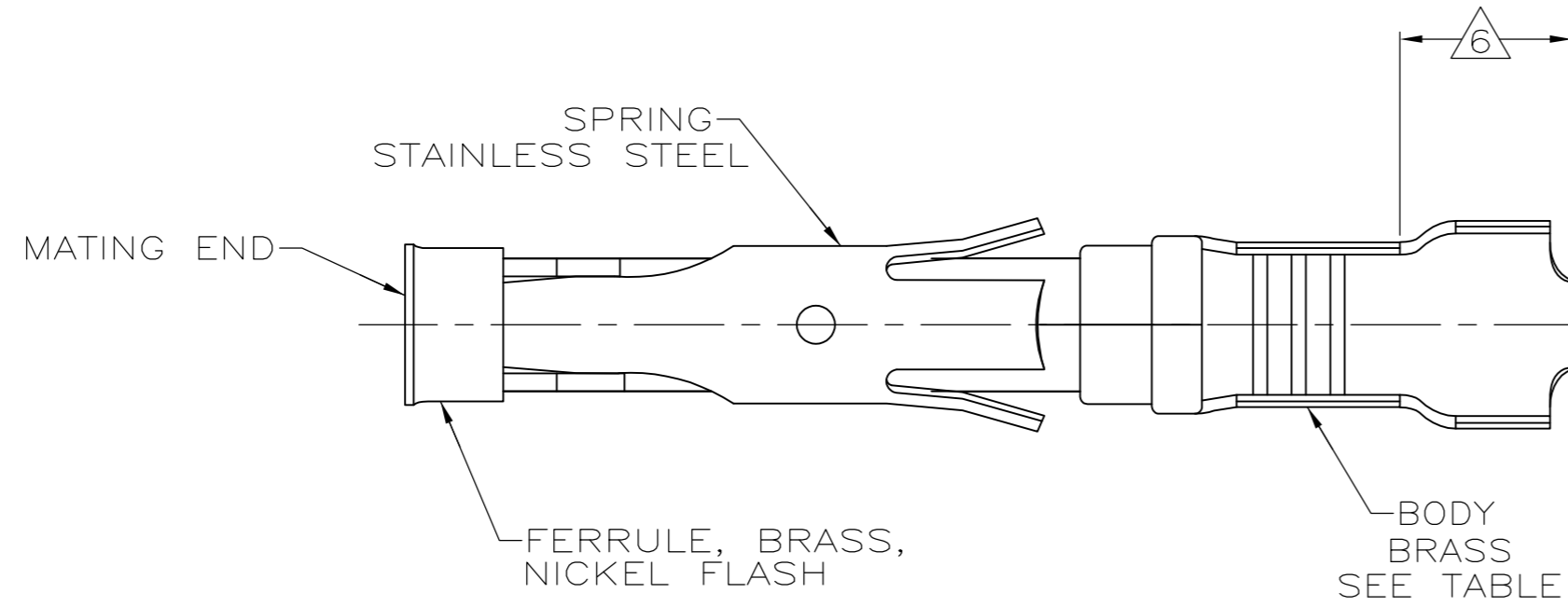

SECTION B-B

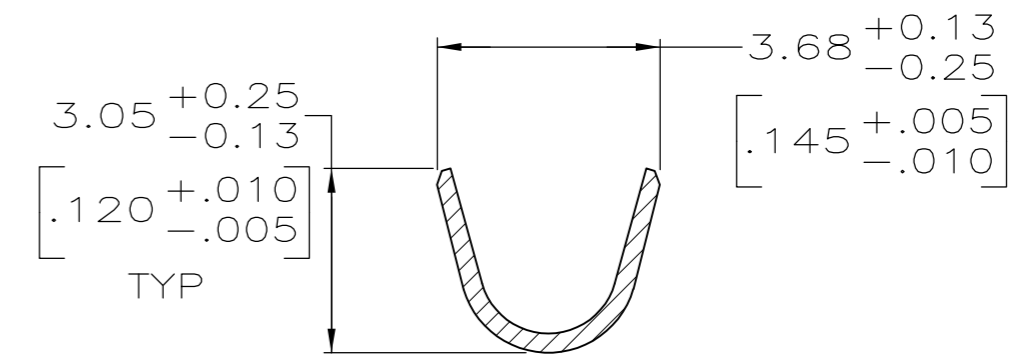

SECTION A-A

- 1 0.76µm [.000030] MIN GOLD PER MIL-G-45204 ON MATING END FOR A LENGTH OF 5.08 [.200] MIN WITH 1.27µm [.000050] MIN MATTE TIN PLATE IN WIRE CRIMP AREA, BOTH OVER 0.76µm [.000030] MIN NICKEL PER QQ-N-290.
- 2 1.27µm [.000050] MIN TIN-LEAD PER MIL-T-10727 OVER 0.76µm [.000030] MIN NICKEL PER QQ-N-290.
- 3 0.76µm [.000030] MIN GOLD PER MIL-G-45204 ON MATING END FOR A LENGTH OF 5.08 [.200] MIN WITH A UNIFORM GRADIENT TO 0.25µm [.000010] MIN GOLD PER MIL-G-45204 ON THE REMAINDER OVER 0.76µm [.000030] MIN NICKEL PER QQ-N-290.
- 4 0.38µm [.000015] MIN GOLD PER MIL-G-45204 ON MATING END FOR A LENGTH OF 5.08 [.200] MIN WITH 1.27µm [.000050] MIN MATTE TIN PLATE IN WIRE CRIMP AREA, BOTH OVER 0.76µm [.000030] MIN NICKEL PER QQ-N-290.
- 5 0.38µm [.000015] MIN GOLD PER MIL-G-45204 ON MATING END FOR A LENGTH OF 5.08 [.200] MIN, 1.27µm [.000050] MIN TIN-LEAD PER MIL-T-10727 FOR A LENGTH OF 5.69 [.224] MIN ON OPPOSITE END, BOTH OVER 1.27µm [.000050] MIN NICKEL PER QQ-N-290 ON ENTIRE CONTACT.
- 6 GOLD PLATING NOT REQUIRED IN THIS AREA.
- 7 WIRE RANGE 18-16 AWG. INSULATION RANGE 2.03 [.080]-2.54 [.100].
- 8 1.27µm [.000050] MIN TIN PER MIL-T-10727 OVER 0.76µm [.000030] MIN NICKEL PER QQ-N-290.

SMALL PACK	8	1-66100-9	2-66101-0
STANDARD	8	1-66100-9	1-66101-9
SMALL PACK	1	66100-4	1-66101-8
SMALL PACK	4	66100-3	1-66101-7
SMALL PACK	2	66100-2	1-66101-6
SMALL PACK	3	66100-1	1-66101-5
STANDARD	5	1-66100-7	1-66101-4
STANDARD	1	66100-4	66101-4
STANDARD	4	66100-3	66101-3
STANDARD	2	66100-2	66101-2
STANDARD	3	66100-1	66101-1
PACKAGING TYPE	BODY	STRIP P/N	PART NO

THIS DRAWING IS A CONTROLLED DOCUMENT.		DWN	05/29/92	
DIMENSIONS: mm [INCHES]		CHK	L.SIPE 6-11-92	
TOLERANCES UNLESS OTHERWISE SPECIFIED:		W.LENKER		
0 PLC ± -		APVD		
1 PLC ± -		G.STEINHAUER 7-7-92		
2 PLC ± 0.13 [.005]		NAME		
3 PLC ± -		SOCKET ASSEMBLY, LOOSE PIECE, TYPE III+		
4 PLC ± -		SIZE		
ANGLES ± -		CAGE CODE		
MATERIAL SEE CALLOUTS		DRAWING NO		
FINISH SEE CALLOUTS		A2 00779 C-66101		
WEIGHT		RESTRICTED TO		
CUSTOMER DRAWING		SCALE		
		8:1		
		SHEET		
		1 OF 1		
		REV		
		E		